

# Time Domain Simulation for Multiconductor Transmission Line Model with Frequency Dependent Parameters

Agnieszka Wardzińska  
 Poznan University of Technology,  
 Faculty of Electronics and Telecommunications  
 Poznań, Poland  
 agnieszka.wardzinska@put.poznan.pl

Wojciech Bandurski  
 Poznan University of Technology,  
 Faculty of Electronics and Telecommunications  
 Poznań, Poland  
 wojciech.bandurski@put.poznan.pl

**Abstract**— In the paper, a fast and effective method of modeling a coupled interconnect in time domain using the SPICE simulator by means of S-parameters is presented. The model of transmission line with frequency dependent parameters is considered. The approach bases on the method of successive approximations. The rational approximation of the matrix of per-unit-length parameter of the line is done. The parameters are calculated for each frequency. The main advantage of the approach is the ability to implementation in SPICE simulator. The approach gives good results for low-loss interconnects. The results of such implementation of the scattering parameters are presented for the low-loss transmission line.

**Keywords**— *Interconnect, VLSI, Scattering Parameters, Transmission Line, Spice*

## I. INTRODUCTION

The time domain modeling of the VLSI interconnects are still ongoing challenge even the literature on this subject is very rich. The faster and smaller circuits make the topic still open. The parameters of the interconnects depend on the frequency and the couplings cannot be neglected. Especially the inductance influence becomes more important, and some interconnect must be considered as low-loss interconnects. Then there is a need to develop new methods to effectively take into account these problems. In the paper, we refer to two methods, which can be applied to solve the problem. The first solution [2] base on the dyadic Green's function and vector fitting of per-unit-length impedances and admittances of the transmission line to obtain a matrix  $Z$  of n-port of the multiconductor transmission line. Every entry of matrix  $Z$  is the sum of the rational functions of a complex frequency  $s$ , which facilitates the transformation to the time-domain. There is possibility to model the circuit in SPICE but the large number of terms in every entry of the matrix  $Z$  must be taken into account. The paper [3] introduce a method of conversion of differential telegrapher's equations into integral equations and next solve them through successive approximation. In that approach, there is obtained a simple analytical form of the first-order approximation of the solution. The method is valid for

lowloss transmission lines. The drawback of that approach was not including the skin effect and dielectric dispersion.

In the presented approach we base on the method of successive approximations like in [3], but we take into account the line parameters' dependence on frequency. For this purpose, as in [1,2,7], we employ the concept of rational approximation of the matrix of per-unit-length line parameters calculated for each frequency. We rely on the scattering parameters of a n-wire transmission line. Such parameters for both frequency and time domains was obtained in [1]. We presented our approach for example of single interconnect in [7]. In this paper, we present the results of the implementation of the model in the SPICE simulator for coupled interconnects.

The paper is organized as follows. In section II, the integral equations approach to the dispersive transmission line are presented. In section III, the method of successive approximation to calculate the scattering parameters of the multiconductor line and display the proposed model in SPICE are applied. In the section IV, the exemplary transmission line calculations are presented. In section V the conclusion is done.

## II. TELEGRAPHER'S EQUATIONS IN INTEGRAL FORM

### A. Telegrapher's equations for a dispersive multiconductor transmission line

Let us consider a multiconductor transmission line consisting of  $N$  conductors and a ground plane. The telegrapher's equations are as follows:

$$\begin{aligned} -\frac{d\mathbf{V}(p,y)}{dy} &= (\mathbf{Z}_o(p) + \mathbf{Z}_1(p)) \mathbf{I}(p,z) \\ -\frac{d\mathbf{I}(p,y)}{dy} &= (\mathbf{Y}_o(p) + \mathbf{Y}_1(p)) \mathbf{V}(p,y) \end{aligned} \quad (1)$$

where

$$\begin{aligned} \mathbf{Z}_o(p) &= \mathbf{R} + p\mathbf{L}, & \mathbf{Y}_o(p) &= \mathbf{G} + p\mathbf{C} \\ \mathbf{Z}_1(p) &= \sum_{m=1}^{N_z} \frac{\mathbf{R}_m^z}{p + p_m^z}, & \mathbf{Y}_1(p) &= \sum_{m=1}^{N_y} \frac{\mathbf{R}_m^y}{p + p_m^y} \end{aligned}$$

$\mathbf{R}, \mathbf{L}, \mathbf{G}, \mathbf{C}$  – matrices of per-unit-length parameters

The presented work has been funded by the Polish Ministry of Science and Higher Education within the status activity task 2016 in "Development of methods for the analysis of propagation and signal processing"

$y = z/d$ ,  $\tau = t/T$ ,  $p = sT$ ,  $T = d\sqrt{L_{11}^o C_{11}^o}$   
 $d$ -length of the line  
 $L_{11}^o$  - entry of original inductance matrix  
 $C_{11}^o$  - entry of original capacitance matrix

In (1), matrices  $\mathbf{Z}_1$  and  $\mathbf{Y}_1$  are the rational forms of per-unit-length impedance and admittance of the multiconductor transmission line obtained [2], by means of the vector fitting technique [5]. In the next step the partial decoupling of the multiconductor transmission line is performed. It is done [3], by matrix transformations:

$$\begin{aligned}
 \mathbf{U} &= \mathbf{XV}, & \mathbf{J} &= \mathbf{P}^{-1}\mathbf{I} \\
 -\frac{d\mathbf{U}(p,y)}{dy} &= (\mathbf{X}^{-1}\mathbf{R}\mathbf{P}^{-1} + \mathbf{p}\mathbf{X}^{-1}\mathbf{L}\mathbf{P}^{-1} + \\
 & \mathbf{X}^{-1}\mathbf{Z}_1(p)\mathbf{P}^{-1})\mathbf{J}(p,z), & (2) \\
 -\frac{d\mathbf{J}(p,y)}{dy} &= (\mathbf{P}\mathbf{G}\mathbf{X} + \mathbf{p}\mathbf{P}\mathbf{C}\mathbf{X} + \mathbf{P}\mathbf{Y}_1(p)\mathbf{X})\mathbf{V}(p,y),
 \end{aligned}$$

where:

$$\mathbf{X} = \mathbf{L}^{\frac{1}{2}}\mathbf{W}\mathit{diag}\left[\frac{1}{\sqrt{\lambda_k}}\right], \quad \mathbf{P} = \mathit{diag}[1/\sqrt{\lambda_k}]\mathbf{W}^{-1}\mathbf{L}^{\frac{1}{2}}$$

$\mathbf{W}$ ,  $\lambda_k$  -eigenvector and eigenvalues of matrix  $\mathbf{L}^{\frac{1}{2}}\mathbf{C}\mathbf{L}^{\frac{1}{2}}$ .

Equation (2) is partially decoupled, and matrices  $\mathbf{X}^{-1}\mathbf{L}\mathbf{P}^{-1} = \mathbf{P}\mathbf{C}\mathbf{X}$  are diagonal. The current waves by matrix transformation can be written as follows:

$$\begin{bmatrix} \mathbf{I}_- \\ \mathbf{I}_+ \end{bmatrix} = \frac{1}{2} \begin{bmatrix} \mathbf{1} & -\mathbf{1} \\ \mathbf{1} & \mathbf{1} \end{bmatrix} \begin{bmatrix} \mathbf{U} \\ \mathbf{J} \end{bmatrix} = \mathbf{S} \begin{bmatrix} \mathbf{U} \\ \mathbf{J} \end{bmatrix}.$$

After some matrix manipulation a new form of the telegrapher's equations can be presented:

$$\begin{aligned}
 \frac{d}{dy} \begin{bmatrix} \mathbf{I}_- \\ \mathbf{I}_+ \end{bmatrix} + \mathbf{p} \begin{bmatrix} -\mathbf{\Lambda} & \mathbf{0} \\ \mathbf{0} & \mathbf{\Lambda} \end{bmatrix} \begin{bmatrix} \mathbf{I}_- \\ \mathbf{I}_+ \end{bmatrix} &= \begin{bmatrix} \mathbf{P}_1 & -\mathbf{P}_2 \\ \mathbf{P}_2 & -\mathbf{P}_1 \end{bmatrix} \begin{bmatrix} \mathbf{I}_- \\ \mathbf{I}_+ \end{bmatrix} + \\
 \begin{bmatrix} \mathbf{Q}_1 & -\mathbf{Q}_2 \\ \mathbf{Q}_2 & -\mathbf{Q}_1 \end{bmatrix} \begin{bmatrix} \mathbf{I}_- \\ \mathbf{I}_+ \end{bmatrix}, & (3)
 \end{aligned}$$

where

$$\begin{aligned}
 \mathbf{P}_1 &= \frac{1}{2}\mathbf{X}^{-1}(\mathbf{X}^{-1}\mathbf{R}\mathbf{P}^{-1} + \mathbf{P}\mathbf{G}\mathbf{X}), \\
 \mathbf{P}_2 &= \frac{1}{2}\mathbf{X}^{-1}(\mathbf{X}^{-1}\mathbf{R}\mathbf{P}^{-1} - \mathbf{P}\mathbf{G}\mathbf{X}), \\
 \mathbf{Q}_1 &= \frac{1}{2}\mathbf{X}^{-1}(\mathbf{X}^{-1}\mathbf{X}^{-1}\mathbf{Z}_1(p)\mathbf{P}^{-1} + \mathbf{P}\mathbf{Y}_1(p)\mathbf{X}), \\
 \mathbf{Q}_2 &= \frac{1}{2}\mathbf{X}^{-1}(\mathbf{X}^{-1}\mathbf{X}^{-1}\mathbf{Z}_1(p)\mathbf{P}^{-1} - \mathbf{P}\mathbf{Y}_1(p)\mathbf{X}).
 \end{aligned}$$

In (3) the diagonal entries of matrix  $\mathbf{P}_1$  are moved to the left side and after some manipulations the formula (4) is obtained.

$$\begin{aligned}
 \frac{d}{dy} \left[ \exp[-(\mathbf{P}_{1k,k} + p\mathbf{\Lambda})] \mathbf{I}_- \right] &= \exp[-(\mathbf{P}_{1k,k} + \\
 p\mathbf{\Lambda})] \mathbf{P}'_{10} \mathbf{I}_- - \exp[-(\mathbf{P}_{1k,k} + p\mathbf{\Lambda})] \mathbf{P}'_2 \mathbf{I}_+, & (4a)
 \end{aligned}$$

$$\begin{aligned}
 \frac{d}{dy} \left[ \exp[(\mathbf{P}_{1k,k} + p\mathbf{\Lambda})] \mathbf{I}_+ \right] &= \exp[(\mathbf{P}_{1k,k} + \\
 p\mathbf{\Lambda})] \mathbf{P}'_2 \mathbf{I}_- - \exp[(\mathbf{P}_{1k,k} + p\mathbf{\Lambda})] \mathbf{P}'_{10} \mathbf{I}_+, & (4b)
 \end{aligned}$$

where

$$\mathbf{P}'_{10} = \mathbf{P}_{10} + \mathbf{Q}_1, \quad \mathbf{P}'_2 = \mathbf{P}_2 + \mathbf{Q}_2.$$

## B. Integral equations for a dispersive multiconductor transmission line

Integrating the first of equations (4) from  $y$  to 1, and the second from 0 to  $y$ , we obtain:

$$\begin{aligned}
 \mathbf{I}_-(p,y) &= \exp[-(\mathbf{P}_{1k,k} + p\mathbf{\Lambda})(1-y)] \mathbf{I}_-(p,1) - \\
 \int_y^1 \exp[-(\mathbf{P}_{1k,k} + p\mathbf{\Lambda})(\xi-y)] \mathbf{P}'_{10} \mathbf{I}_-(p,\xi) d\xi + \\
 \int_y^1 \exp[-(\mathbf{P}_{1k,k} + p\mathbf{\Lambda})(\xi-y)] \mathbf{P}'_2 \mathbf{I}_+(p,\xi) d\xi, & (5a)
 \end{aligned}$$

$$\begin{aligned}
 \mathbf{I}_+(p,y) &= \exp[-(\mathbf{P}_{1k,k} + p\mathbf{\Lambda})y] \mathbf{I}_+(p,0) + \\
 \int_0^y \exp[-(\mathbf{P}_{1k,k} + p\mathbf{\Lambda})(y-\xi)] \mathbf{P}'_{10} \mathbf{I}_-(p,\xi) d\xi - \\
 \int_0^y \exp[-(\mathbf{P}_{1k,k} + p\mathbf{\Lambda})(y-\xi)] \mathbf{P}'_2 \mathbf{I}_+(p,\xi) d\xi & (5b)
 \end{aligned}$$

Equations (5) are integral telegrapher's eqs. and can be solved analytically or numerically. We now calculate (5) by means of successive approximations method.

## III. SCATTERING PARAMETERS OF THE MULTICONDUCTOR TRANSMISSION LINE AND THE SPICE MODEL

The first order approximation, not difficult to obtain (see[3]), for equations (5a) has the following form [7]:

$$\begin{aligned}
 \mathbf{I}_-(p,y) &= \\
 e^{-(\mathbf{P}_{1k,k} + p\mathbf{\Lambda})(1-y)} \mathbf{I}_-(p,1) - \\
 \int_y^1 e^{-(\mathbf{P}_{1k,k} + p\mathbf{\Lambda})(\xi-y)} \mathbf{P}'_{10} e^{-(\mathbf{P}_{1k,k} + p\mathbf{\Lambda})(1-\xi)} d\xi \mathbf{I}_-(p,1) + \\
 \int_y^1 e^{-(\mathbf{P}_{1k,k} + p\mathbf{\Lambda})(\xi-y)} \mathbf{P}'_2 e^{-(\mathbf{P}_{1k,k} + p\mathbf{\Lambda})\xi} d\xi \mathbf{I}_+(p,0), & (6)
 \end{aligned}$$

Substituting  $y=0$  in (6) we obtain the relationships:

$$\begin{aligned}
 \mathbf{I}_-(p,0) &= \\
 \int_0^1 e^{-(\mathbf{P}_{1k,k} + p\mathbf{\Lambda})(\xi-0)} \mathbf{P}'_2 e^{-(\mathbf{P}_{1k,k} + p\mathbf{\Lambda})\xi} d\xi \mathbf{I}_+(p,0) + \\
 \left[ e^{-(\mathbf{P}_{1k,k} + p\mathbf{\Lambda})(1-y)} \right] - \\
 \int_0^1 e^{-(\mathbf{P}_{1k,k} + p\mathbf{\Lambda})(\xi-0)} \mathbf{P}'_{10} e^{-(\mathbf{P}_{1k,k} + p\mathbf{\Lambda})(1-\xi)} d\xi \mathbf{I}_-(p,1). & (7)
 \end{aligned}$$

In (7), we can easily identify the scattering parameters as:

$$\mathbf{S}_1(p) = \int_0^1 e^{-(\mathbf{P}_{1k,k} + p\mathbf{\Lambda})(\xi-0)} \mathbf{P}'_2 e^{-(\mathbf{P}_{1k,k} + p\mathbf{\Lambda})\xi} d\xi \quad (8a)$$

$$\mathbf{S}_2(p) = \int_0^1 e^{-(\mathbf{P}_{1k,k} + p\mathbf{\Lambda})\xi} \mathbf{P}'_{10} e^{-(\mathbf{P}_{1k,k} + p\mathbf{\Lambda})(1-\xi)} d\xi. \quad (8b)$$

## A. Scattering matrices in the frequency domain

Calculation of integrals (8) is straightforward and the results are following

$$\begin{aligned}
 \mathbf{S}_1(p)_{m,i,j} &= \left[ \mathbf{P}_{2i,j} + \mathbf{Q}_2(p)_{m,i,j} \right] \cdot \\
 \frac{1 - \exp\left(-(\mathbf{P}_{1i,i} + \mathbf{P}_{1j,j} + p(\lambda_i + \lambda_j))\right)}{\mathbf{P}_{1i,i} + \mathbf{P}_{1j,j} + p(\lambda_i + \lambda_j)}, & (9a)
 \end{aligned}$$

$$S_2(p)_{m,i,j} = e^{-(P_{1,i,i}+p\lambda_i)} + \left( P_{10,i,j} + Q_1(p)_{m,i,j} \right) \frac{e^{-(P_{1,i,i}+p\lambda_i)} + e^{-(P_{1,j,j}+p\lambda_j)}}{P_{1,i,i} - P_{1,j,j} + p(\lambda_i - \lambda_j)}, \quad (9b)$$

where

$$Q_{1/2}(p)_{m,i,j} = \frac{1}{2} \left[ \frac{Z_{2m,i,j}}{p+p_m^z} + /- \frac{Y_{2m,i,j}}{p+p_m^z} \right],$$

$$Z_{2m,i,j} = [X^{-1}R_m^z P^{-1}]_{i,j}, \quad Y_{2m,i,j} = [PR_m^z X]_{i,j},$$

### B. SPICE model

For n-wire transmission line we prepared the model which uses the derived form of scattering parameters. The model is presented in Fig. 1. As we presented in Section II using matrices X and P we performed a partial decoupling of the n-wire transmission lines. The decoupled model obtained by this procedure is illustrated in Fig. 2.

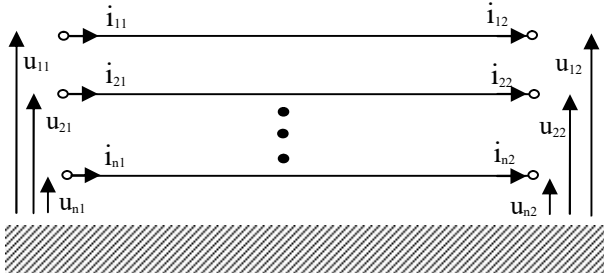

Fig.1 Multiconductor (n-wire) transmission line.

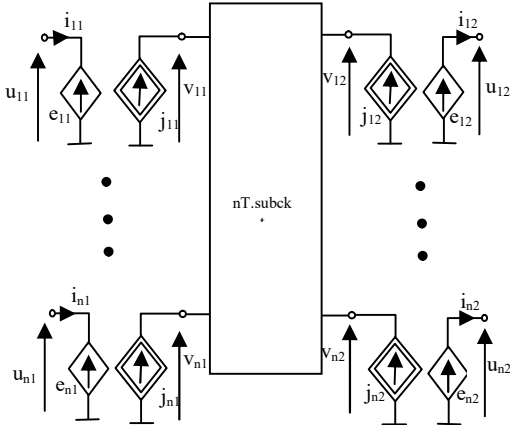

Fig. 2. SPICE model of a multiconductor transmission line, where

$$e_{k,1/2} = \sum_{m=1}^n x_{k,m} v_{m,1/2}, \quad j_{k,1/2} = \sum_{m=1}^n p_{k,m} i_{m,1/2}.$$

Based on equations (10) and (9), for the partially decoupled transmission lines model we create a subcircuit (nT.subckt) using scattering parameters. Fig. 3 shows an equivalent circuit of the k-th transmission line ( $k = 1, \dots, n$ )

$$I_-(p, 0) = S_1(p)I_+(p, 0) + S_2(p)I_-(p, 1), \quad (10a)$$

$$I_+(p, 1) = S_2(p)I_+(p, 0) + S_1(p)I_-(p, 1) \quad (10b)$$

where

$$I_-(p, 0) = \mathbf{b}_1(p), \quad I_+(p, 1) = \mathbf{b}_2(p),$$

$$I_+(p, 0) = \mathbf{a}_1(p), \quad I_-(p, 1) = \mathbf{a}_2(p).$$

### IV. RESULTS

As an example three wire transmission line (microstrip transmission line) is considered. Its cross-section is shown in Fig.4. The per-unit-length matrices  $Z_0$ ,  $Z_1$ ,  $Y_0$  and  $Y_1$  were calculated by means of program LINPAR [4] in seventeen frequency points from 10Hz to 2.1GHz. Next there was approximated by rational functions using vector fitting algorithm [5], [6] to obtain the form as in (1). The approximated matrices  $Z_0$ ,  $Z_1$ ,  $Y_0$ , and  $Y_1$  were used next to calculate all parameters needed for calculation scattering matrices  $S_1(p)$  and  $S_2(p)$  in frequency domain.

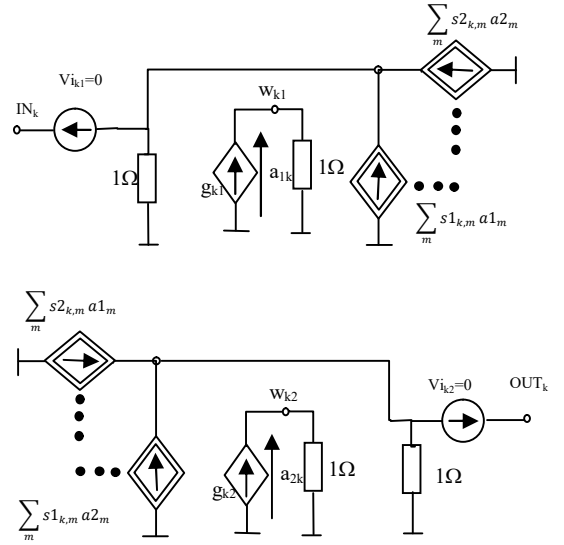

Fig. 3. Subcircuit nT.subckt (Fig.2),  $k,m = 1, \dots, n$ .

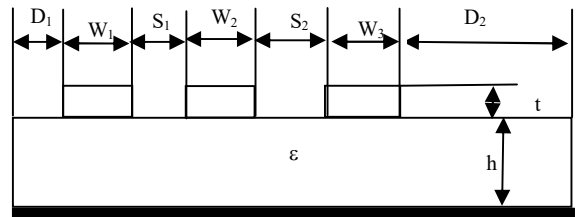

Fig.4 Microstrip data:  $W_1=100\mu\text{m}$ ,  $W_2=100\mu\text{m}$ ,  $W_3=600\mu\text{m}$ ,  $h=625\mu\text{m}$ ,  $s_1=300\mu\text{m}$ ,  $s_2=280\mu\text{m}$ ,  $t=30\mu\text{m}$ ,  $\text{tg}\delta=10^{-4}$ ,  $\epsilon_r=4.7$ ,  $D_1=800\mu\text{m}$ ,  $D_2=800\mu\text{m}$ ,  $d=0.2\text{m}$ .

The self resistances of the three transmission lines as a functions of frequency, calculated by means of LINPAR [4], are shown in Fig.5. The simulated circuit consists of voltage pulse sources  $V_s$  (of the trapezoid shape  $A = 2\text{V}$ ,  $T_r = T_f =$

500ps,  $T_{on} = 2\text{ns}$ ) with source resistance  $R_1=50\Omega$ , and a transmission lines loaded as it is shown in Fig.6.

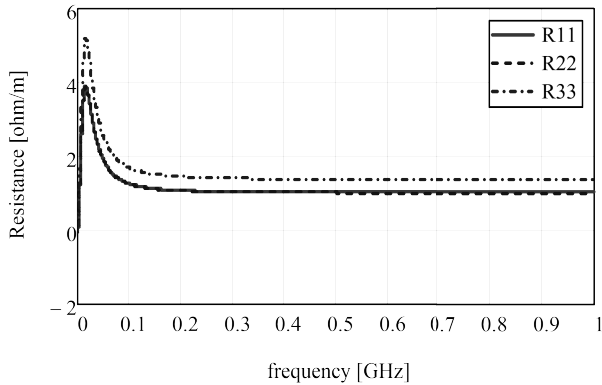

Fig. 5. Dependence of shunt conductance and shunt reactance of the line on frequency.

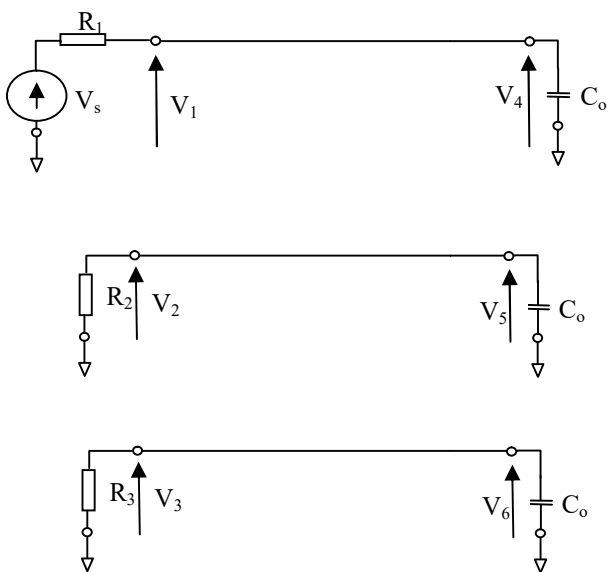

Fig. 6. Considered three wire transmission line circuit,  $R_1=R_2=R_3=50\Omega$ ,  $C_o=1\text{pF}$ .

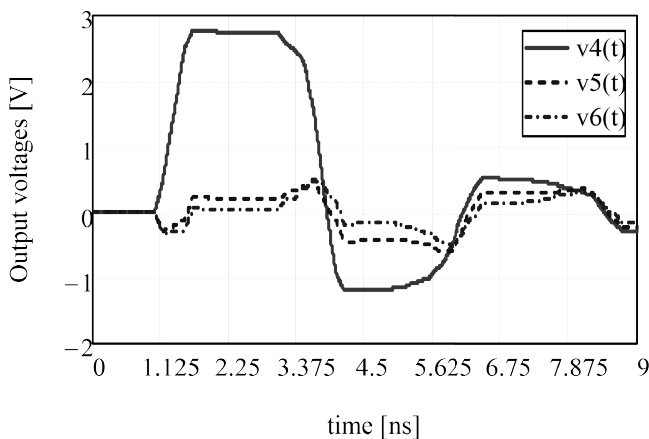

Fig. 7. Voltages at the far ends.

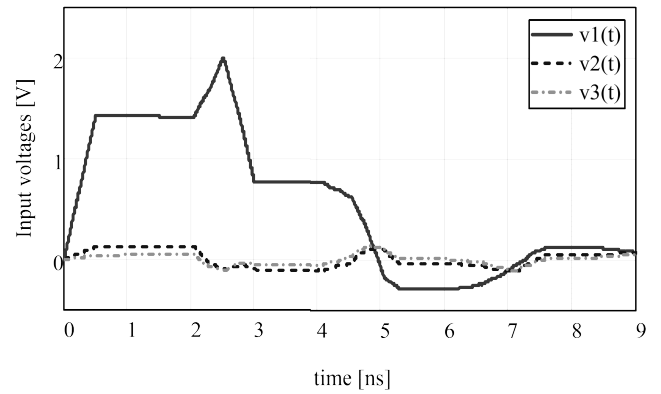

Fig. 8. Voltages at the near ends.

The voltages at the input and output lines for both sets of data are shown in Figs 7-8. These figures illustrate the pulse distortion caused by the skin effect and dielectric permittivity dependence on frequency.

#### V. CONCLUSIONS

We have shown that it is possible to generalize an approach based on the method of successive approximation for the case of a multiconductor transmission line with frequency-dependent parameters. As a result, we obtain a closed form (meaning a first-order approximation) of the scattering parameters of the multiconductor transmission line both in the frequency and time domains. In the case of a low-loss transmission line, the approximation gives very good results. Compared to the approach based on the dyadic Green's function [2], the presented approach is simpler, of course, assuming sufficiently small losses of the multiconductor transmission line. The presented approach permits the implementation of the model in SPICE. Currently, we are working on the implementation of the model of a n-wire transmission line in the SPICE program.

#### REFERENCES

- [1] A. Wardzińska, W. Bandurski, "Multiconductor Transmission Line Scattering Parameters in Time Domain", 18th IEEE Workshop on Signal and Power Integrity, Ghent, May 11-14, 2014.
- [2] G. Antonini, "A dyadic Green's function based method for transient analysis of lossy and dispersive multiconductor transmission lines", *IEEE Tran MTT*, vol. 56, No.4, April 2008, pp. 880-895.
- [3] W. Bandurski, "Simulation of single and coupled transmission lines using time-domain scattering parameters", *IEEE Tran CAS-I*, vol. 47, No.8, August 2000, pp. 1224-1234.
- [4] A. Djordjević, R. F. Harrington, T. Sarkar, M. Baždar, "Matrix parameters for multiconductor transmission lines", Artech House, 1989.
- [5] B. Gustavsen, A. Semlyen, "Rational approximation of frequency domain response by vector fitting", *IEEE Transactions on Power Delivery*, vol.14, no. 3, 1999, pp. 1052-106.
- [6] <http://www.sintef.no/Projectw>
- [7] A. Wardzińska, W. Bandurski "Multiconductor Transmission Line Model with Frequency Dependent Parameters in Time Domain" 22nd European conference on circuit theory and design, Trondheim, Norway, August, 2015.