



POLITECHNIKA POZNAŃSKA

FACULTY OF INFORMATION TECHNOLOGY AND
TELECOMMUNICATIONS

BACHELOR'S ENGINEERING THESIS
ARTIFICIAL LOAD FOR AUDIO MEASUREMENTS

Wojciech Rościszewski-Wojtanowski 140062

Promoter:

dr. inż. Łukasz Matuszewski

POZNAN 2021

1. Contents

2.	List of Tables and Figures	3
3.	Introduction.....	5
3.1	Purpose and scope of work.....	5
3.2	Audio Amplifiers - Introduction.....	5
3.3	Acoustic Measurement Method	8
3.4	Artificial Load Measurement Method	10
4.	Background	13
4.1	Biology of Audio Spectrum Hearing	13
4.2	Audio Transmission Characteristic.....	14
4.3	Audio Amplifiers and Parameters.....	15
5.	Deeper Dive into Audio Analysis, Research	19
5.1	Resistors	19
5.2	Capacitors.....	23
5.3	Inductors.....	30
5.4	Transistors	31
5.5	Audio Amplifiers and Parameters Analysis	32
6.	Plan and Design Approach.....	35
6.1	Artificial Dummy Load Product Research	35
6.2	Common Issues with Amplifier and Artificial Dummy Loads	38
6.3	Artificial Load Design Stage Evaluation.....	41
7.	Design Technical Implementation	46
7.1	Production Plan.....	46
	Artificial Load Construction and Production Stage.....	49
7.2	Setting up the Testbed (Using Audio Card, Amplifier, Computer, Oscilloscope to test an Amplifier Circuit)	55
7.3	Hardware and Software Measurement Techniques and Analysis Evaluation.....	56
7.4	Improvements to Design in the Future	59
8.	Conclusion	62
9.	References.....	64

2. List of Tables and Figures

List of Tables

Table 5.1 Presents the Comparison Data for Resistor types and their prices, including models.....	21
Table 5.2 Presents Most Important Features of Capacitors. [21].	26
Table 5.3 Capacitor State Analysis a LCR meter Comparison.	28
Table 6.1 Presents the USD Price Comparison between Aluminium and ABS Raw Materials as of 7.1.2022.	45
Table 7.1 Presents a set of construction as well as production steps taken to complete the artificial load prototype.	49

List of Figures

Figure 3.1 Presents Harman Kardon HK3770 Amplifier inside. [1].	5
Figure 3.2 Presents Radmor 5100 76r. (Personal Collection).....	6
Figure 3.3 Acoustic Pressure Characteristics Measured in an Anechoic Chamber Unitra Tonsil ZG-30- C115. (Personal Collection).....	8
Figure 3.4 Presents an exemplar connection of artificial load through sound card taken from source [7], “Amplifier research circuit using Sound Blaster X-FI HD RightMark Audio Analyzer and Zelscope”. ...	10
Figure 3.5 Presents Right Mark Audio Analyser (RMAA) Software from resource [8].	12
Figure 4.1 Functional Diagram of the Human Ear.....	13
Figure 4.2 Presents Input / Output Sections of an Amplifier.	14
Figure 4.3 Presents LTSpice Simulation Results of Two Audio Signals. [11].	14
Figure 4.4 Presents a Common Emitter Amplifier Circuit, from source [13].....	16
Figure 4.5 Presents Class A Amplifier Continuation, from source [14].....	16
Figure 4.6 Presents Bridge Mode Amplifier, modified example from source [15]	17
Figure 4.7 Presents a Linear Audio Auto ranging Attenuator, from source [16]......	18
Figure 5.1 Presents European and North American Resistor Circuit Symbol Difference [20].....	20
Figure 5.2 Graph Presenting Data of Resistor Type Prices from TME.EU 01/2022.	21
Figure 5.3 Resistors 100W 4 Ohm 1% Tolerance used for Audio Measurements (Personal Photo).....	22
Figure 5.4 Presents Resistors 10kΩ with 1% Tolerance used for audio measurement project (Personal Photo).....	23
Figure 5.5 Presents capacitor symbols, as stated in the source, “Capacitors. The curved electrode indicates the negative terminal of the polarized capacitor, or the "outer foil" of a wrapped-film capacitor.” [19].....	23
Figure 5.6 Presents cross-section perspective of construction and electrolyte comparison, as stated in source, “(A, B) Cross-sectional view of a typical device. (C) Electrolyte capacitors of various shapes and sizes” [22]	24
Figure 5.7 Old Capacitor 1 (220μF).....	28
Figure 5.8 New Capacitor 1 (220μF)	28
Figure 5.9 Old Capacitor 2 (220μF).....	28
Figure 5.10 New Capacitor 2 (220μF)	28
Figure 5.11 Presents a set of various size inductors from resource [30] “A selection of low-value inductors”.....	30

Figure 5.12 Presents an inductor from resource [19]. “Inductors. The parallel-bar symbol represents a core of magnetic material.....	30
Figure 5.13 Presents 2N6491G ONSEMI Transistor (Source: [31].....	31
Figure 6.1 Presents an Artificial Dummy Load ($4/8\Omega$) PKNW-23-01 from source: [34]	36
Figure 6.2 Presents Insides of Artificial Dummy Load PKNW-23-01 from source: [34]	36
Figure 6.3 Presents an Artificial Dummy Load ($4/8\Omega$) built by Krzysztof Popiel, source: [36].	37
Figure 6.4 Presents Insides of Artificial Dummy Load built by Krzysztof Popiel, source: [36].	37
Figure 6.5 Presents a Labelled Diagram of the Final Artificial Load Design and Key Interface Screens Breakdown.	42
Figure 6.6 Presents a Google Sketchup Model of the Artificial Load Design with Front Panel perspective.	43
Figure 6.7 Presents a Google Sketchup Model of the Artificial Load Design Top View with Front Panel Perspective.	43
Figure 7.1 Presents the Artificial Load Schema.....	46
Figure 7.2 Presents Output Stage Voltage Divider Theoretical R11 and R12 (R2) Calculations.	47
Figure 7.3 Presents a Labelled Arduino Module Connection Schema used for Artificial Load.....	48
Figure 7.4 Presents a block diagram of Artificial Load Overview	48
Figure 7.5 Presents Basic Block Diagram of Setup Needed for Testing Using RMAA Software.....	55
Figure 7.6 Presents Basic Block Diagram of Setup Needed for Testing Using Oscilloscope	55
Figure 7.7 Input Signal of 12kHz Function Generator at 4 Ohms Resistance Set on Artificial Load	56
Figure 7.8 When LCD is Drawing Current, we Observe Interference.....	57
Figure 7.9 Right Mark Audio Analyser - Good Results.	57
Figure 7.10 RMAA Final Results	58
Figure 7.11 Presents an AC supply socket with filter (3A, 250VAC), model FYB03T1 produced by YUNPEN ELECTRONIC. As stated in manufacturers documentation, [42], “General purpose filter with IEC connector providing effective line-to-ground noise up to 15 amp”.....	59

3. Introduction

3.1 Purpose and scope of work

This diploma project focuses on measurement of audio using an artificial dummy load device. This work will also be an investigation into other possibilities of audio measurements using artificial dummy loads. Inspiration from taken from my vintage audio equipment renovation passion as well as in recent times - fashion.

3.2 Audio Amplifiers - Introduction

Home audio systems have been popular for decades and are, like the clothing fashion industry - it changes. In the present day, our technology is much more advanced in comparison to what we had over 45 years ago – let’s take for example a modern-day amplifier. The first noticeable detail about such device is that it mostly consists of *Integrated Circuits (IC’s)*, *Surface-Mounted Devices (SMD)* components and multi-layer *Printed Circuit Boards PCBs*. In the below please find Figure 3.1, this image has been taken from a very popular Polish audio forum [1], it is a relatively newly made amplifier produced by a company called Harman Kardon, model HK-3770.

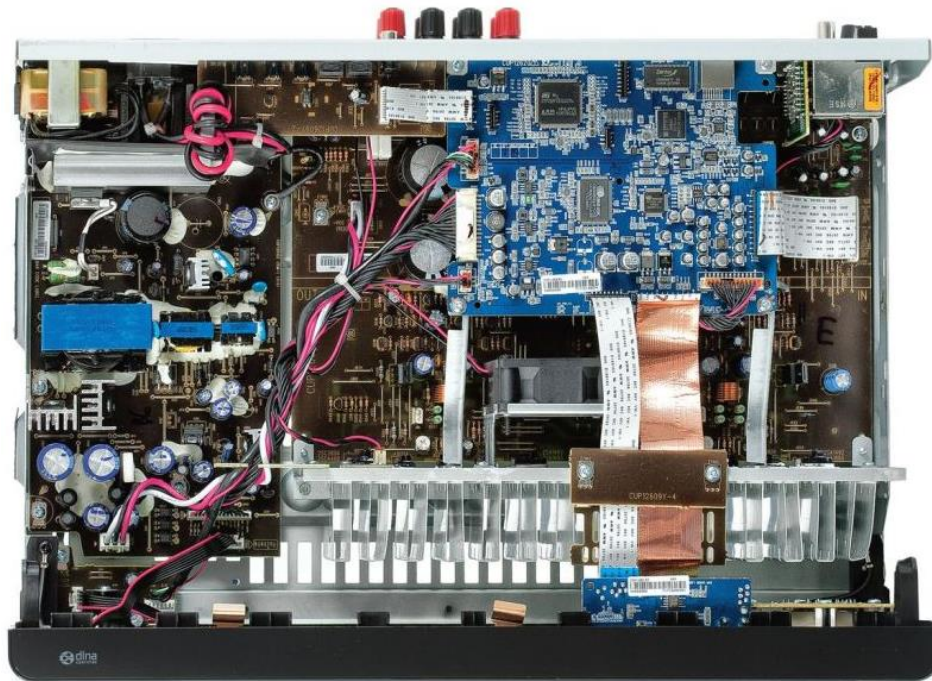

Harman Kardon HK 3770

Figure 3.1 Presents Harman Kardon HK3770 Amplifier inside. [1].

As seen in the above Figure 3.1, the amplifier consists of a few boards, these boards are divided say into modules, where we see the *Power Supply Unit (PSU)* module on the left side of the device, whilst to the right we can see some sort of controller board (blue colour) that looks to be the “brain” of the device – presumably it processes communication between the front panel and the visible IC’s.

Commonly newer amplifiers also have built-in *Wireless Fidelity (Wi-Fi)*, Bluetooth, *Infra-Red (IR)* modules that enable different sorts of things such as, wireless radio over internet streaming from services such as Spotify [2]. They can also offer connecting to a mobile device via. Bluetooth technology, or even be controlled remotely with use of an IR remote. With that in mind, we can move on forward and compare the insides of this amplifier to something older, such as a Polish-make amplifier Radmor 5100, with its production started in the end of 1975 in Gdynia – at first request for the military. It is a 47-year-old amplifier; therefore, it won’t possess modern-day quantities such as Wi-Fi, Bluetooth ICs, or IR sensors. In the below, please see Figure 3.2 presenting the separate PCB modules of such mentioned device.



Figure 3.2 Presents Radmor 5100 76r. (Personal Collection).

As presented in the figure in the above, visible is the forementioned Radmor 5100 amplifier. We see that this device has all of its modules on separate boards, making it very pleasant to service as under the 4 boards on the top (that are responsible for controlling programmer and receiving radio) there are also 4 other boards (responsible for amplification at output stage to 4 Ω speakers as well as pre-amplification stage of a turntable input). Continuing, I would like to also point out that we see a lot of foil capacitors, old Russian-make (red) M&T resistors, Polish Telpod potentiometers and some logic gate ICs produced by CEMI, another old Polish company. During that time, in Poland, there were many companies however most of them shutdown due to their financial/political status - [3]. However, today some of them are reactivated such as Telpod [4].

The purpose of this introduction was to present the technological difference between these similar devices, since they are both amplifiers. With only difference that the oldest one (Radmor) is much cheaper and easier to handle in comparison to the latest one (Harman Kardon) due to its SMD components that require specialistic tools, microscope, hot air gun, small tip soldering iron, IC iron tips, etc. to replace if damaged where in Radmor we only require a multimeter and a soldering iron for most of its service.

With that short beginning, we can clarify that today development of modern audio equipment is quite precise, compared to older generation equipment – with new kinds of technological advancements. However, it should also be included that today's modern equipment provides less opportunity for repair and this is due to the construction of these devices and since they use small SMD components, which an everyday consumer will not be able to repair by themselves. This is due to lack of correct equipment, tools as well as knowledge. Whereas, in older amplifiers these components were much larger and less complex, thus making them easier to repair with some background knowledge of course, for example desoldering a resistor and placing in a new one. Moving on forward, within a few years there has been a rise in popularity of older generation audio equipment, they've become popular due to their "retro" design, aluminium panels and even the performance - however we won't be focusing on comparing performance of old day to modern day audio equipment, yet I'm sure such comparison of parameters would be interesting. As stated before, this topic is similar to the fashion industry, it changes but somehow repeats its cycle.

3.3 Acoustic Measurement Method

Newer amplifiers might be difficult to fix, as mentioned in 3.2, in comparison to vintage audio equipment. However, if over time we were to not compare these different generations of audio devices, we would lose track of advancements. Therefore, it would be very difficult to analyse, measure and even repair them – especially without knowing which kind of tools are required. Expanding this thought, what purpose does an amplifier have, if we don't have or know which speakers to connect to? Sometimes these devices are sometimes collected for decorative purposes. However, an amplifier without speakers it will just not operate as per its design, therefore we can infer that it requires some sort of load for the current to travel to. Some older amplifiers did not have protection against this, and turning them on without any load would simply damage the power amplifier itself - modern day audio equipment is protected from such mistakes.

In a situation when we have a “new” piece of equipment on our workbench, let's say we need to perform maintenance on some 40-year-old amplifier, we will need to connect the speakers to something so that we can perform our measurements and analysis of device state. The easiest way to test if our amplifier is working is to connect a load, speakers in this instance, and play some music. However, when this is done, we're in fact only checking if music is in fact amplified/played-back through our device – what we don't know is if the played-back audio is in fact correct since all speakers have their own specific acoustic characteristic – for example, in the 80's/90's Unitra Tonsil produced a pair of speakers Zg-30-C115 with 8Ω impedance and a range of 50 – 20 kHz. [5] that out of the factory had their characteristic printed on badges as seen in the Figure 3.3 found in the below.



Figure 3.3 Acoustic Pressure Characteristics Measured in an Anechoic Chamber Unitra Tonsil ZG-30-C115. (Personal Collection).

As visible in the figure above, we see a sound pressure (acoustic pressure) of our entire speaker cabinet, this is just the atmospheric pressure change due to sound deviation, usually we measure this in special anechoic chambers filled with suitable microphones. Sound can be defined as “a pressure variation (wave) that travels through air and is detected by the human ear” [6] provides a strong description of this – and in this particular example by the microphones. In our example, since we’re attempting to check the output sound via our speakers, then we must also consider the factor of noise. Noise is also just as sound a pressure variation, however it is something we’re not looking for – “Excessive or unwanted sound which potentially results in annoyance and/or hearing loss” [6] also provides another strong description of this. Concluding, we cannot test an amplifier overly accurately purely relying on what we are provided with acoustically.

Therefore, in order to see the data, we’re looking for we should refer to bandwidth characteristics, as we must also consider that all devices are different – especially vintage audio amplifiers, have capacitors that degrade and have different values refer to chapter 5.2. The forementioned bandwidth analysis, one of which can be the frequency response test showing use the change of amplitude, we can also gather other analytical methods such as frequency range, non-linearity, pass band ripple, phase response and even in stereo systems cross talk between two channels – commonly the lower the better, lowest commonly found in full-mono systems (one amplifier for one channel). This information can also be acquired from source [7], where it is mentioned “In the case of electroacoustic signals, the transmission characteristic comes down to two values, the frequency response of which is commonly known and used with the parameters of the bandwidth (frequency range) and the unevenness of the transmission in this band (pass band ripple).” To sum up, we have two types of characteristics with one having the signal amplifier into the speakers generating acoustic pressure from, which we gather a characteristic whilst the other being the pure bandwidth characteristic of the device itself which of course is the most desirable characteristic for the focus of this thesis.

3.4 Artificial Load Measurement Method

With being aware of the forementioned method we can connect our device under test to a dummy load, that in return will act as our speaker, in this thesis I will avoid considering capacitance and inductance properties since this device should be simple – true resistive load. From such dummy load we can gather data from, which we can judge the performance of our amplifier. This method is the primary concept of this thesis, it will be outlined on how semiconductor elements operate for us to understand how to firstly think of constructing such load. The key problem here is that today vintage audio popularity is rising, meaning more people will want to renovate/service their equipment and without correct apparatus we cannot complete such task, therefore this such dummy load measurement device is my proposed solution to this problem. As through our artificial dummy load we're able to gather data if the receiver is working correctly as well as diagnosing potential problems such as bad filtering from power supply module, interference generation, uneven channel performance, etc.

Designing such artificial load connection isn't difficult in the day of the Internet, as most things can be found via. various sources – I prefer to stay to books hence why please see in the below an example Figure 3.4 of a dummy load, in this case a $4 \times 470\Omega$ artificial load connected to the input port of the sound card (Karta Sound), whilst the output of the card is connected to the input port of amplifier (Wzmacniacz). In this example, the author of the book did not hesitate to limit the capabilities of artificial loads and further analysed vinyl record players and as visible in the Figure 3.4 CD players – which also is a returning in popularity music format.

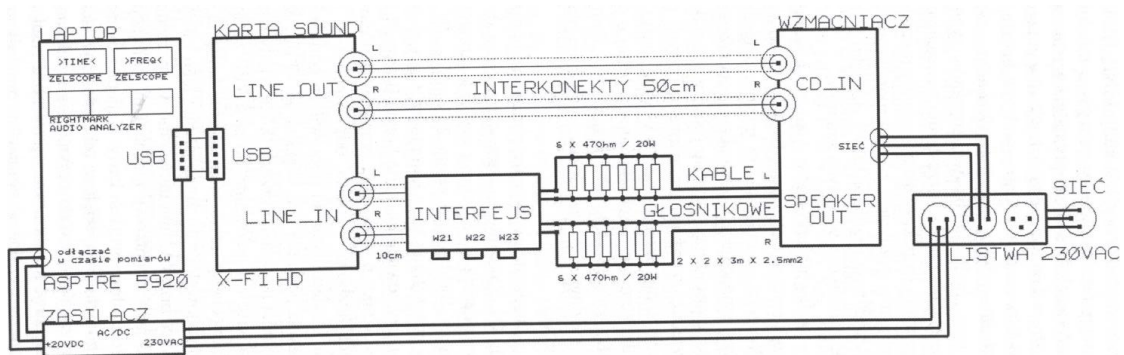

Figure 3.4 Presents an exemplar connection of artificial load through sound card taken from source [7], “Amplifier research circuit using Sound Blaster X-FI HD RightMark Audio Analyzer and Zelscope”.

As seen in the above the example is quite detailed, provides a broad overview of how the connections should be made. For this thesis for analysis, we will connect in a similar fashion. With regards to hardware parts, the sound card that will be used for this thesis will be the Creative Sound Blaster X-FI, in fact this is the same sound card as recommended by source [7]. The reason of this is that the sound card has a decent bitrate in comparison to other cards available at that price range – I have purchased this card at the price of 200 PLN in 2021 and due to increase in audio restoration interest I fear that these cards will increase in value. It will be ideal to look for a successor card before such situation occurs, since during measurements it is very easy to burn the sound card – in fact this is the next topic.

In audio measurements using the artificial load, we must remember that we should limit the input signal coming into the sound card from the amplified load signal, this is because we might overload the *Digital Sound Processor (DSP)* and essentially burn it – yes, I have done this and for sake of continuation of this project another card was bought at the same price. To limit the incoming sound, we should add a, let's say $20k\Omega - 22k\Omega$ potentiometer to limit the input to the card and avoid further damage. Therefore, this is a crucial step, we all learn by mistakes, however in an event where coils (inductors, as discussed in upcoming chapter 5.3) of the sound card begin to act as small speakers and play the sound we will know that the card is overloaded, and the DSP might fail. In addition to hardware discussion, please note that in Figure 3.4, the source author has used interconnect cables, else known as *Radio Corporation of America (RCA)*, has limited the length to a maximum of 50 cm, this is a well-known factor that cable length affects audio quality therefore we should consider the shortest and most reasonable cable length. It would be ideal if the interconnect cables were to have extra shielding layers to avoid noise and interference coming into the design.

Using the software, however, is a much different story since we must only select appropriate options in order to proceed with are audio measurements. We can perform various measurements, and of course, having the option of which measurements we would like to focus on.

The software sends a set of 24-bit signals, that are looped back into the sound card input since the sound card used in this thesis as well as suggested in resource [7] we can with confidence use 24-bit audio mapping. In the below, please see a screen-grab of the options found in the Right Mark Audio Analyser software provided from resource [8].

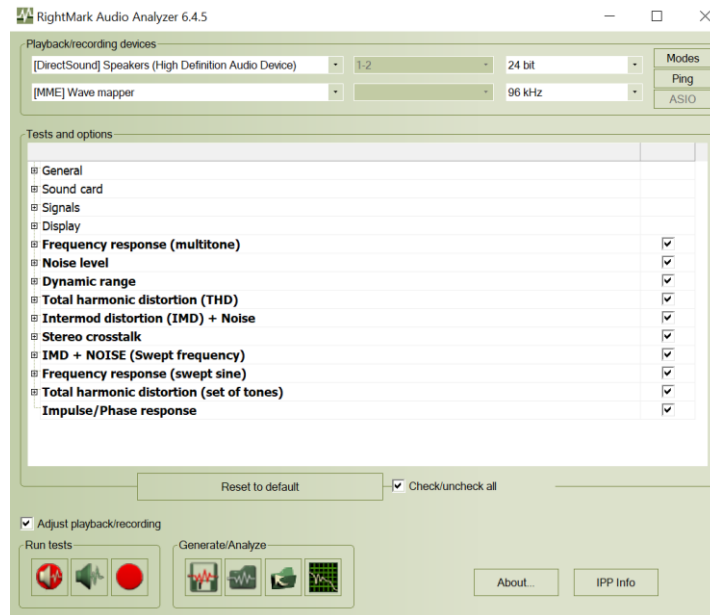

Figure 3.5 Presents Right Mark Audio Analyser (RMAA) Software from resource [8].

4. Background

4.1 Biology of Audio Spectrum Hearing

The way in which living organisms have developed over billions of years of evolution is truly fascinating, especially sensory abilities commonly referred to as the somatosensory pathways of our nervous system. This can be vision (sight), olfaction (smell), gustation (taste), tactile perception (touch) and others. Yet, our focus will be the human perception of sound (hearing). Within this background section, it will be described on how the evolutionary force of nature enabled us to adapt our hearing to certain audio spectrums. In the present day we know that we as humans are able to detect sounds within the frequency of 20 Hz up to 20 kHz, however it is common that more mature people might have less high-frequency sensitivity. This is confirmed in the Audible Spectrum – Neuroscience book, “Humans can detect sounds in a frequency range from about 20 Hz to 20 kHz. (Human infants can actually hear frequencies slightly higher than 20 kHz but lose some high-frequency sensitivity as they mature; the upper limit in average adults is often closer to 15–17 kHz.)”, [9]. In Figure 4.1 found in the below presented is the anatomy of the human ear is visible, it is a quite simple breakdown focusing on the high to low stages, resource [10].

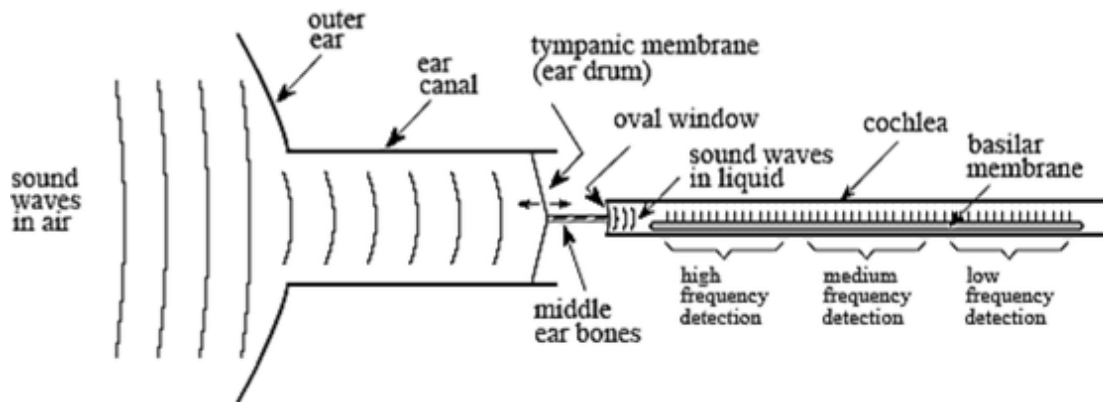

Figure 4.1 Functional Diagram of the Human Ear.

4.2 Audio Transmission Characteristic

The devices in our focus can be divided into various classes, depending on their offered quality of audio transmission characteristic – more on this will be discussed in the next chapter, “Audio Amplifiers”. For us to determine the correctness of our signal transmission through our system we must firstly consider the input path signal, this’ll be the source as well as the output path of our signal, which’ll be the audio signal exiting the amplifier system (amplified output). In the figure below, please see a diagram presenting the comparison method described in the above.

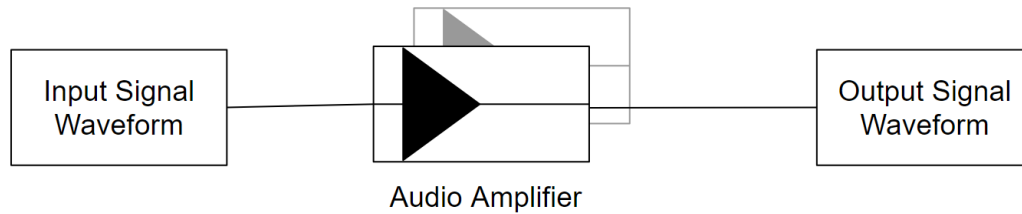

Figure 4.2 Presents Input / Output Sections of an Amplifier.

As seen in the above connection and audio transmission, we are able to measure the output waveform/signal that has been amplified and then compare it to our input waveform. As a result, we are given the data to analyse how the amplifier performs, such as how the filters work, how the Tremble or Bass settings manipulate the signal. To clarify, I will provide a personal example from a CAD (Computer Aided Design) laboratory report (validated by/supervisor: Dr. Sławomir Michalak) within, which we analysed the construction as well as functionality of filters in an amplifier circuit. Below, please see a comparison of two signals. This example is provided in order to visualize how important checking for performance correctness is in amplifiers, cheap amplifiers tend to be constructed with limited budgets whilst the higher up we go in the price ladder we will see that all of the semiconductor components used in amplifiers are of higher quality – e.g., construction of filters found in an audio circuit of an amplifier.

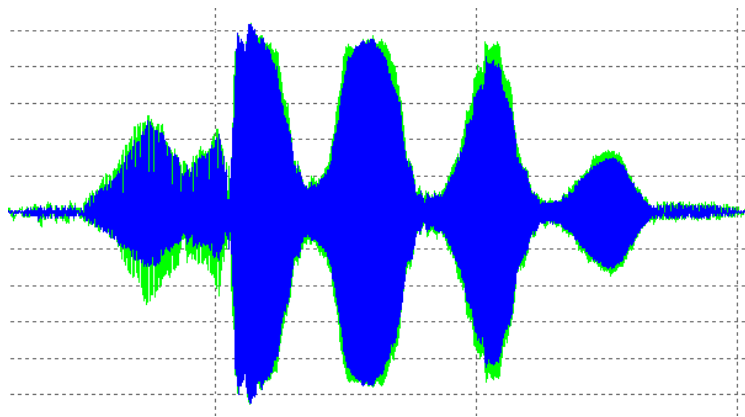

Figure 4.3 Presents LTSpice Simulation Results of Two Audio Signals. [11].

As seen in the above example we have the green displaying an ideal amplifier playing back bird sounds ideally – however we must stay cautious as in electronics nothing is ideal, we instead refer to accuracy in this case. As it is visible, we have the blue signal, the output of the filtered amplifier circuit, that had removed certain frequencies from our audio spectrum – resulting in sound loss. In this example, the intention was to remove noise from a sample audio file and with reference to the original report we can conclude, “After hearing the two files, I hear that the noise has been reduced successfully I hear no static, but the noise of the birds is slightly quieter. Notice on the output characteristics that the filtered output has much smoother curves, suggesting less noise in comparison to the unfiltered output.” [11].

4.3 Audio Amplifiers and Parameters

Since we will be working on audio equipment, it would be beneficial to expand and essentially focus on how amplifiers operate, why testing is important and even why noise and shielding or certain components is useful.

There are various types of amplifiers, commonly we have amplifiers in our home audio systems to play our music, whilst we also have amplifiers in HAM radios, RC toys, televisions, computers etc. Our focus in this thesis is on audio amplifiers and how we test them. But we should also take into consideration other factors, such as what type of amplifier it is – vacuum tube or transistor based. These are two separate technologies, where vacuum tube circuits operate at an *Alternating Current (AC)* voltage, so touching any of the components whilst the amplifier is turned on isn't recommended. Transistor based amplifiers operate at *Direct Current (DC)* voltage, so they're definitely a little safer to handle – also remembering that they're fed AC voltage into the transformer, so extra care should be considered at all times as it seems.

The size of this equipment varies from their class, I am not including the features they have since it is possible to today buy a vintage amplifier as well as a new one packed with Wi-Fi, Bluetooth etc. and still being the same size. Unless there is an isolated transformer to reduce noise, then size is usually the same. Commonly, the bigger they are the more expensive they seem to be. On the downside its common that, users do not have space for such heavy and large equipment and often buy smaller devices.

Whilst on the topic of storage, I believe it's worth not note that temperature stability is quite important. Storing an amplifier in a warm and dry environment will for sure expand the lifetime of that device, since semiconductor elements operate at their ideal parameters as well as little moisture will not degrade any of the elements – for example, from my experience I've stored vintage audio equipment in a cool environment, when bringing it into a warmer room I've found that the difference of temperature enabled moisture to form on the exterior as well as interior of the amplifier. After inspection, I've found that some more corrosion has developed, therefore it is important that these devices are stored in dry environments.

Amplifier designs vary from different configurations, however the simplest and most common of them all is the NPN common emitter amplifier, for this design we will use a transistor that enables higher voltage gain, therefore simply speaking smaller voltage enters its base whilst a larger voltage (amplified) exits through the collector. For purpose of research an example has been found in resource [12], where “base is the input, the collector is the output, and the "common" or ground is the emitter” meaning that the amplification is done by the transistor and resistors in the circuit. Expanding on these resistors play a very important role next to transistors, therefore when restoring vintage audio equipment, it is beneficial to check if resistive element satisfies all parameters as behaviour of transistor is influenced by these elements. In the below, please find Figure 4.4 that presents such exemplar construction.

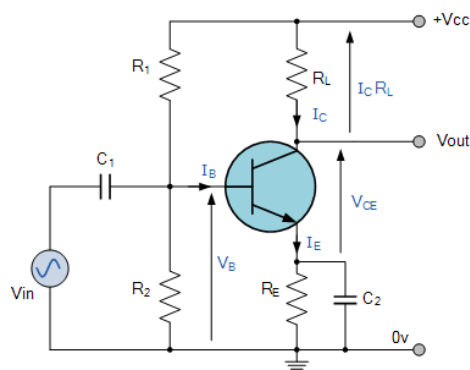

Figure 4.4 Presents a Common Emitter Amplifier Circuit, from source [13]

As seen in the above Figure 4.4, this in fact is a Class A type amplifier – that has as little distortion as it could possibly have from. This type of amplifier operates linearly, where the input signal is the same as the output signal. For all of this to occur, we must firstly select an appropriate transistor for this design, by finding the quiescent point (Q-point) of DC line. With a correct Q-point, let’s say at 10V of input the collector will be standing at 5V, so ideally as half when there is no signal – meaning that when a signal is passed through it is not cut-off. In the below, please see Figure 4.5 expanding the forementioned Q-point and how we perceive it.

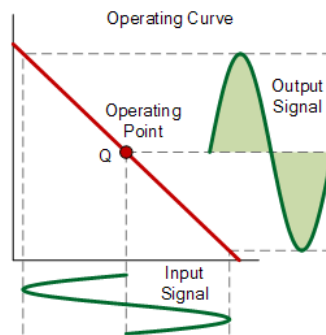

Figure 4.5 Presents Class A Amplifier Continuation, from source [14]

Testing such amplifiers in a home environment isn't very beneficial nor useful, since without correct equipment diagnosing if an amplifier requires service, or if it's faulty, is just not very possible. For testing amplifiers, we need to view how the signal is processed through our device, we also need to see how it behaves under certain loads, or if when turning on it doesn't produce a constant component that could destroy the speakers. Therefore, dummy artificial loads are used for this. Usually, when packaged with necessary features, can provide quite excellent results. However, we must remember that we do not live in an ideal world, and we must approach each task with some degree of pre-thought as not all amplifiers unfortunately can be connected to the artificial this project focuses upon – resulting, so we can damage the amplifier and end up with a lot of emotional stress. The artificial load explored in this thesis will be used for most types of amplifiers that require a separate ground connection. An example of an amplifier that should not be connected to the artificial load safely is an amplifier that works in a bridge mode. This is a situation when we cannot connect further test equipment such as an oscilloscope as later described. First of all, in the below please see an example Figure 4.6 showing schematic of how to characterise such amplifier.

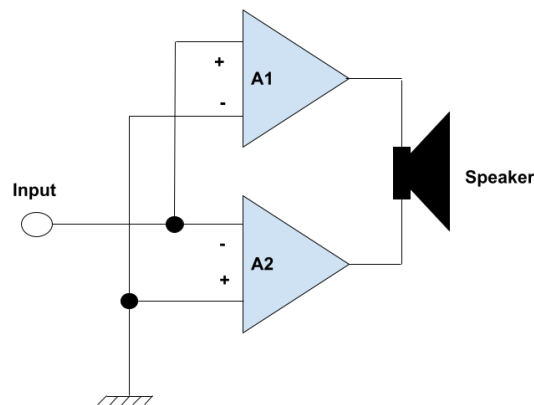

Figure 4.6 Presents Bridge Mode Amplifier, modified example from source [15]

To clarify, the amplifier of course can be connected to the artificial load however any other measurement equipment should not be connected, such as an oscilloscope. The reasoning of this is that in bridging mode, as seen in Figure 4.6, none of the poles are constantly connected to ground. In addition to this, we must also remember that an oscilloscope probe is always connected to ground potential. As a result, connecting these two mediums will result in a short circuit and damage the test measurement apparatus (our oscilloscope) as well as our amplifier. A resolution of this problem would be using measurement apparatus that isn't grounded – an example of such can be a simple mobile oscilloscope commonly used in car diagnostics, an exemplar model of such oscilloscope can be the Siglent SHS810. Another potential resolution to this problem is use of a differential oscilloscope probe, however those are quite expensive – but most definitely cheaper than a new device. In my opinion the first option would be most suitable, due to mobility benefits.

Next on the list is a more or less continuation of audio measurement, so how amplifier can be tested, this was discussed in chapters 3.3 and 3.4. The methods are quite unique, however since we are discussing parameters of such amplifiers, in 3.4 I have discussed the use of a software RMAA. This is a fantastic piece of software; it does a really good job – however as all good things happen, we must also consider the worst to avoid disappointment. It is a well-known factor that professional grade measurement equipment and software costs a lot of money, with this taken into consideration we must note that this is a free of use piece of software. A method of checking if the signal produced from the sound card (which of course is another factor on the pile to affect accuracy) would be passing the signal through a Linear Audio Auto ranging Attenuator, such device has been constructed by Jan Didden and enables to provide very accurate results such as voltage readings ensuring that the signal coming out of our sound card is in fact in correct range. In the below please find Figure 4.7 presenting the forementioned device. Unfortunately, due to time and budget constraints I was not able to get hold of such device, however since this is a prototype design, and I am sure that this can be omitted – in the future when improvements are to be made this would be a very beneficial tool to obtain.



Figure 4.7 Presents a Linear Audio Auto ranging Attenuator, from source [16].

Without a doubt this isn't the only method to be used for audio measurements, of course we can get hold of basic amplifier parameters by simply connecting a function generator to the *auxiliary (AUX)* stage port of the amplifier. For example, a FeelElec FY6900-100M [17] budget function generator will be more than enough to complete such task, on the other hand the cheapest method would be downloading a function generator application on a smartphone such as Keuwlsoft function generator [18] and playing it through the AUX port – however, that isn't very accurate as I've found as a mobile device sound card also has its limitations such as, unfortunately, noise.

In conclusion, amplifier construction is very important, and we must always refer to the schematics or build construction. We must also consider parametric issues and percentage of reasonable error.

5. Deeper Dive into Audio Analysis, Research

For the next part of my research, I would like to approach the components typically found in audio equipment, such as amplifiers. To begin this section, I will firstly focus on the passive elements, since we want to begin with the basics first. Later within the chapters more details will be covered such as amplifier parameters and analysis, this will include important details for this project.

5.1 Resistors

Resistive components are widely used components that reduce the amount of current flow within a circuit. Without resistance in any circuit current will not flow, this is the result of the Ohm's law principle.

$$R = \frac{V}{I} \quad [19]$$

where

R = Resistance

V = Potential Difference

I = Current

From this, we can infer that a resistor is able to regulate the current flow in our circuit. Most resistive components out there do not contain any components of capacitance and inductance. Commonly, resistors are used to deliver the correct voltage to transistors, so let's say within an audio amplifier such resistors will most likely be found next to transistors. They also have a common use as fuses, when too much current flows they would burn up and detach the electrical connection.

The next point that I would like to cover is the meteorological symbol of resistors, in measurements - especially audio measurements it is important for us to know the two symbols used to represent a resistive component. The importance of this is high, since if such a component is affecting the performance of our measurements, then it must be replaced however, to do this we must firstly identify it on a circuit schema, for example of an amplifier. In the figure below, please see two symbols that both represent a resistor. The European symbol is a rectangle, whilst the North American is a zigzag pattern like shape.

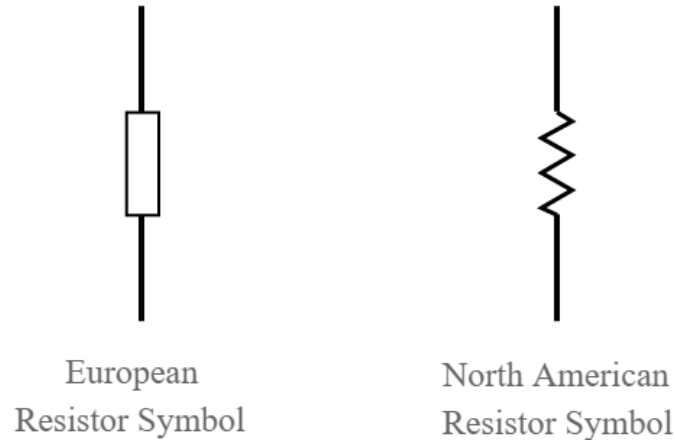

Figure 5.1 Presents European and North American Resistor Circuit Symbol Difference [20]

Moving on forward, what is quite important is the construction of a resistor. This is to help understand how this component operates, especially during audio measurements. We have various types of resistors. Carbon film resistors are made with the use of hydrocarbons that are cracked onto the ceramic folder, which in return outputs our carbon film. These films are then cut into pieces that enable us to select the parameters we need them to be. However, it should be noted that an ideal resistor will only have resistive component (so no inductance or capacitance) yet in this case carbon film resistors can be inductive and as a result of this they cannot be used in radio frequency applications especially in audio systems, yet they can be found in audio systems just not in the audio path. This is because inductance will not comply with the resistance, it will in fact resist that current change. Metal film resistors are usually made from a nickel alloy, overall, the process is similar to carbon film resistors, instead they just use a metal oxide film. Either way, a metal film resistor has good performance in terms of the temperature coefficient, since the carbon film resistors sometimes require some temperature before they adjust to their correct values whilst meta films have a much wider temperature coefficient ($\pm 15^{\circ}\text{C}$). Last of all I would like to mention wire wound resistors, usually these types of resistors are wounded by a special former (hence the name wire wound), and are usually found in higher power cases, commonly these have a heatsink fitted around them enabling the head to be dissipated away from the component.

The last thing I would like to mention is tolerance of a resistor, where it is the percentage error of the resistor's resistance itself. Usually, we tend to use the metal film resistors in audio electronics due to their 1% high accuracy tolerance. "Usually their absolute value isn't important, however their temperature stability and time stability, harmful inductance and noise." [21]. Therefore, we must take this into consideration that using metalized film resistors is just a better alternative from carbon film resistors since they are more accurate and provide less non-linear results. However, it must be taken into consideration that there is a price and usually metal film resistors tend to be more expensive than carbon film ones – due to their low non-linear distortions and accuracy. In the below please see a comparison of prices, the prices found have been taken from a well-known wholesaler TME.EU. For this purpose, I've selected the cheapest and ordered them from cheapest to most expensive.

Table 5.1

Presents the Comparison Data for Resistor types and their prices, including models.

Resistor Type [1W]	Model [100Ω]	Price + Tax (as of January 2022)
Carbon Film Resistor	CF1WS-100R	0.12530 [PLN/EACH]
Metal Oxide Resistor	MOF1WS-100R	0.24950 [PLN/EACH]
Metal Film Resistor	MF01SFF1000A10	0.33950 [PLN/EACH]
Wire Wound Resistor	KNP01UJ0101A10	0.57200 [PLN/EACH]

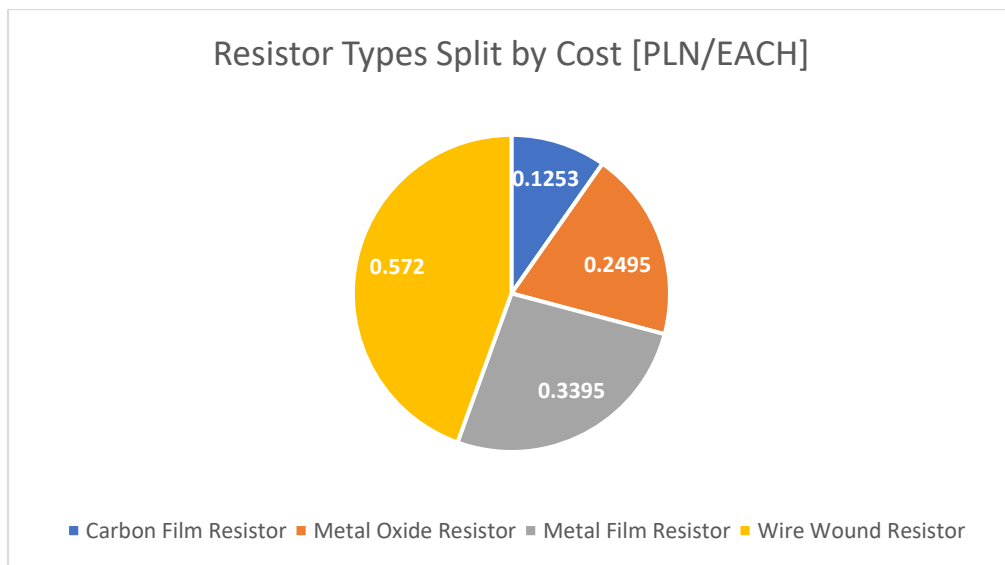

Figure 5.2 Graph Presenting Data of Resistor Type Prices from TME.EU 01/2022.

In the above graph Figure 5.2, please see all of the forementioned resistor types and prices as in Table 5.1 above. Most expensive is the wire-wound resistor, with carbon film being the cheapest. The metal film resistors have a higher popularity hence why the demand price is higher than the metal oxide resistors, this is due to the nature of the metal oxide resistor that generates more noise (but does handle po. Therefore, the most ideal resistor for let's say measurement devices would be the metalized resistor, due to its low noise nature. Furthermore, as mentioned in resource [21] the only use where the 1% tolerance accuracy really matters is when using such components in the differential amplifier. In the below, please see Figure 5.3 presenting photographs of mentioned resistors.



Figure 5.3 Resistors 100W 4 Ohm 1% Tolerance used for Audio Measurements (Personal Photo)

In the figure visible in the above we see a set of wire resistors, hidden within an aluminium shell used to dissipate heat as mentioned previously – these resistors can withstand 100W of power each, therefore these could be potentially very useful for an artificial load. Unfortunately, the limitation of these resistors is that the entire body is aluminium, and this could be problematic since these cannot be directly mounted onto plastic since it would melt.

In the below please see Figure 5.4 presenting another set of resistors, these are the forementioned metal film resistors. These are quite useful since not only are they accurate (1% tolerance) but also relatively small in size, therefore this enables for flexibility. Another use of these resistors could be within a voltage divider circuit – e.g., we would be able to connect an oscilloscope to such voltage divider without using a probe (resulting in just connection of BNC-BNC type ends).



Figure 5.4 Presents Resistors 10kΩ with 1% Tolerance used for audio measurement project (Personal Photo)

5.2 Capacitors

Capacitive semiconductors are passive components such as capacitors, hence the name, can store electrical energy within them just like batteries. In the below please find Figure 5.5 from [19], presenting two capacitor symbols. The first symbol (top) presents a regular capacitor (non-polarized). Whilst the second symbol (bottom) presents a polarized capacitor -hence the +, this is the positive line, else referred to as the anode, see Figure 5.6 (B) from [22]. The curved part in the symbol is the cathode – so the negative connection.

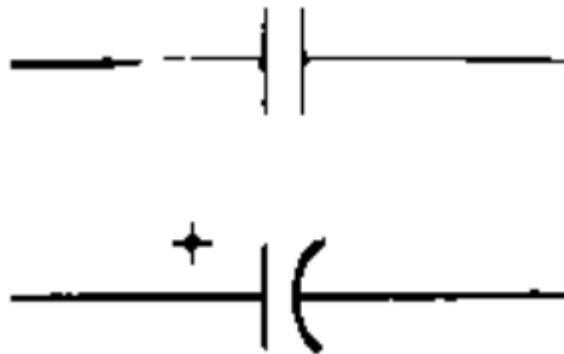

Figure 5.5 Presents capacitor symbols, as stated in the source, “Capacitors. The curved electrode indicates the negative terminal of the polarized capacitor, or the "outer foil" of a wrapped-film capacitor.” [19]

In addition to the forementioned capacitor representation and characterization of polarization, in the below please find a figure presenting these connections are labelled on the capacitors themselves as well as their pin length. Physically, capacitors will have a mark on them, usually a thick line (-) representing the cathode, see (C). In regard to capacitor pin length, the short pin coming out of the capacitor is the cathode whilst the longest pin is the anode, see (A).

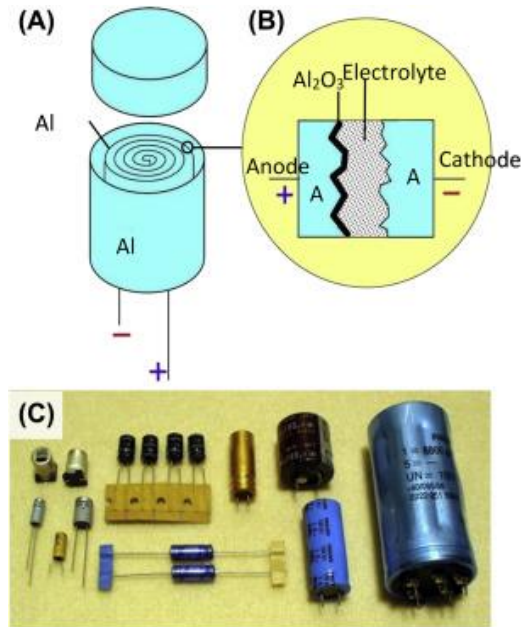

Figure 5.6 Presents cross-section perspective of construction and electrolyte comparison, as stated in source, “(A, B) Cross-sectional view of a typical device. (C) Electrolyte capacitors of various shapes and sizes” [22]

Within many devices such elements are used e.g., in remotely controlled driveway gates or even washing machines, these all have one thing in common. The two mentioned examples use a motor, which requires a higher level of power for a short period of time (start time), then once the motor is operating by itself the capacitor is no longer needed and just disconnects until the next cycle. Although, these elements have a much greater use than just being a temporary battery since they are also able to regulate and filter energy and current flow flowing through our circuit.

Using capacitors within power supplies, let’s say an amplifier, is essential since they filter out the AC component from our current. These are quite sensitive elements in an amplifier since, audio that comes out from our amplifiers is AC coupled therefore to avoid noise/unwanted frequencies in our output signal we must carefully filter out all possibilities. As stated in the official documentation provided by a capacitor manufacturer Kemet, “Capacitors are primarily used for storing electrical charges, conducting alternating current (AC), and blocking or separating different voltages levels of direct current (DC) source.” [23].

Capacitor's capacitance is given in farads, where 1 farad is a coulomb per volt, in the below please see these details from [23]:

$$1 \text{ farad} = \frac{1 \text{ coulomb}}{1 \text{ volt}} \quad [23]$$

1 coulomb represents $\sim 6 \times 10^{19}$ electrons

There are various companies that produce capacitors, just as any semiconductor components. In Poland, we had our own company that produced capacitors, it was called (Unitra) Elwa first created in 1957, "The Radio Components Factory "Elwa" was established by the Minister of Heavy Industry under an ordinance nr 201 z 21.10.1957 r. as the Radio Components Factory under construction." [5]. We also had other such as Miflex, that in fact exists up to this day, it also was created in 1957. "Radio Components Plant "MIFLEX" in Kutno was established in 1957, starting its activity with the production of simple radio capacitors". [24]. We also have others such as WIMA and Nichicon, which are quite popular – today they are at a high demand due to the fact that so many people wish to renovate their vintage or fix their new devices. All of the forementioned companies specialize in various capacitors, in the older days Miflex produced foil capacitors just as now WIMA, whilst Elwa focused on Electrolytic capacitors just as now Nichicon. In the below, please see Table 5.2 presenting very interesting and beneficial breakdown of typical capacitor parameters from source [21].

Table 5.2

Presents Most Important Features of Capacitors. [21].

Capacitor Type	Typical Values	Max. Voltage [V]	Description
Electrolytic	1 μ F to 1 F	6,3 to 450	Mainly for de-energizing
Tantalum	1 μ F to 470 F	6.3 to 50	For decoupling the power supply and signal path
MKT	1 nF to 100 μ F	50 to 630	Popular, inexpensive, for signal path applications
MKP	1 nF to 100 μ F	50 to 630	For use in the signal path
Ceramic (Type 1)	Anything below 10 nF	up to 50	Quite good parameters, universal
Ceramic (Type 2 & 3)	1 nF to 1 μ F	up to 20k	Mainly for de-energizing
KS (Styroflex)	100pF to 6.8 μ F	50 to 630	For applications in the signal path





Before we dive deeper into capacitors and their actual parameters, we must have the knowledge of what is ESR and VLOSS. ESR (else referred to as, Equivalent Series Resistance), it's in a way the resistance of the capacitor and as mentioned in resource [25], "ESR is resistance from a combination of energy loss mechanisms under specific operating conditions." and with this statement we can infer that other mechanisms could be for example amount of time between which the capacitor is charged and discharged through, which we can gather data on how the tested element reacts to applied voltage levels – this is also later described in forementioned resource [25], "capacitance value, ESR defines a time constant for charging and discharging of the capacitor and thus how quickly the capacitor react on voltage/current changes/ripple". Expanding the previous resource, it also includes relative information that, we could also see the ripple changes in the capacitor - this is the alternating current (AC) part of the direct input current (DC), therefore ripple is the AC component within our current and this is also mentioned in resource, ripple when we observe the input current being affected by the load change, as confirmed by in resource [26], "In most electronic devices, the DC current signal applied to a circuit has an AC portion. This AC portion is referred to as the ripple current.". Moving forward, we also have to discuss VLOSS (else referred to as, Voltage Loss), which is the amount of voltage that has been lost by comparing the input and the output end results – these results are usually provided as a percentage since it is a ratio. It is important as we want to know if the capacitor holds its voltage or dissipates it immediately after.

To conclude, I would like to clarify that provided parameters enable us to evaluate the elements suitability to be used in a circuit without causing issues such as failures, lack of power, other semiconductor components destruction, this is also supported by "Knowing the value of ESR is important because it determines the suitability of the component for use in RF power applications. If the ESR value is too high, the self-heating due to $I^2 R$ losses will be too great, and the part will overheat and fail" a journal [27] that is focused on Capacitors in RF application, however I believe that this still applies in audio measurements.

Replacing such capacitors is quite important, as when, for this example let's use electrolytic capacitors, they dry out they lose their parameters. Some tend to lose their capacitance volume, for example a 22 μF might end up having 10nF when measuring with a LCR meter. Another example could be that the resistance of the capacitor changes from let's say typical value of 0.2Ω to 0.6Ω and much more! This is something that we would like to eliminate from some circuit, as the parameters will be undesired from the intended design. In the table below, Table 5.3, I have conducted a small experiment to present this issue. Using an LCR meter I have analysed use 30 - 40-year-old Elwa electrolytic capacitors as well as new Nichicon capacitors. For this I have chosen to use two 220 $\mu\text{F}/16\text{V}$ as well as two new replacement capacitors 220 $\mu\text{F}/25\text{V}$, UKZ1E221MHM [28].

Table 5.3

Capacitor State Analysis a LCR meter Comparison.

Old Capacitor	New Capacitor
 <p data-bbox="305 1094 695 1121"><i>Figure 5.7 Old Capacitor 1 (220μF)</i></p>	 <p data-bbox="922 1094 1328 1121"><i>Figure 5.8 New Capacitor 1 (220μF)</i></p>
<p data-bbox="228 1167 773 1251">Parameters: ESR=0.53Ω, Voltage Loss=9.8%, Capacitance=$112.5\mu\text{F}$</p>	<p data-bbox="849 1167 1393 1251">Parameters: ESR=0.16Ω, Voltage Loss=0.6%, Capacitance=$207.7\mu\text{F}$</p>
 <p data-bbox="305 1570 695 1598"><i>Figure 5.9 Old Capacitor 2 (220μF)</i></p>	 <p data-bbox="914 1556 1323 1583"><i>Figure 5.10 New Capacitor 2 (220μF)</i></p>
<p data-bbox="228 1640 773 1724">Parameters: ESR=0.57Ω, Voltage Loss=3.3%, Capacitance=$234.5\mu\text{F}$</p>	<p data-bbox="849 1640 1393 1724">Parameters: ESR=0.23Ω, Voltage Loss=0.6%, Capacitance=$208.4\mu\text{F}$</p>

Within the table found in the above, Table 5.3, we see the forementioned comparison. The evaluation of these results is relatively easy due to how the LCR meter displays information, as seen we see a lot of variation between the new and the old. For this topic, I will refer to “old” capacitors found in Figure 5.7 and Figure 5.9 as well as to “new” capacitors found in Figure 5.8 and Figure 5.10. Firstly, looking at the measured capacitance we see that something is slightly off, since the old capacitors seem to have a larger capacitance whilst new capacitors have a smaller capacitance. Of course, we must remember that this LCR meter is a cheap device that provides us a broad overview of the element tested. However, if we look deeper into the data, we have we see that the older capacitors have a higher voltage loss than new ones, same goes for ESR readings. These are the main cons of electrolytic capacitors and as stated in [29], " Dependency of ageing (e.g., dry-out)" suggests that these capacitors have these higher readings due to them degrading (drying out) over time. ESR is also relatively high, however it is mostly acceptable, high ESR might result in heating of capacitor and ultimately damaging it – this also has been mentioned in [29], “Tendency to self-heat for types with high ESR (thus increasing the process of dry-out)”.

This experiment and evaluation enable knowledge to satisfy the conclusion that such elements as capacitors found in vintage audio equipment require replacement and within a circuit might cause unwanted distortions/results measured on the artificial load. In such example, the artificial load will output such unwanted distortions and with a blink-of-an-eye we know that something is wrong (blink-of-an-eye saying has been used here due to the fact that testing capacitors requires them to be removed from the circuit board, discharged, and tested and as a result becomes a quite lengthy process).

Improvement of this analysis would be analysing the Q-factor of our capacitors, in fact higher-end LCR meters have this option, however this is a matter of budget. Of course, using the Q-factor characteristic that describes the capacitance per potential difference change. Potential difference change is derived from Ohms law (see previous Resistors subchapter).

$$Q = C \cdot V \quad [19]$$

where

C = Capacitance

V = Potential Difference

5.3 Inductors

For this project, I mostly want to draw attention to capacitors in amplifiers and resistors that could be used for an artificial dummy load. However, to keep consistency and once talking about RC components it would be beneficial to include inductors as it is basic knowledge in electronics that may come in handy. In the below please Figure 5.11 find presenting a various set of inductors, from resource [30].

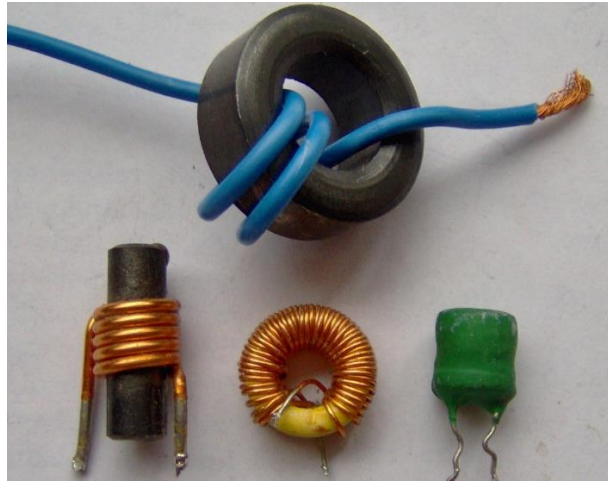

Figure 5.11 Presents a set of various size inductors from resource [30] “A selection of low-value inductors”.

As seen in the forementioned Figure 5.11, we can see various types of inductors. They come in all different sizes, just as capacitors. They also come in SMD form size, making them difficult to replace without expensive equipment.

Inductors just as capacitors are able to store energy, however of course, as can be presumed in a different way. Once a current is flowing through an inductor the energy is stored in a magnetic field, this is supported with information from [30], “a passive two-terminal electrical component that stores energy in a magnetic field when electric current flows through it”. Inductors have an inverse relationship as (it is proportional) to current in comparison with capacitors as stated [19], “They're closely related to capacitors: the rate of current change in an inductor is proportional to the voltage applied across it (for capacitor it's the other way around – the rate of voltage change is proportional to the current though it)”. In the below please find, Figure 5.12 presenting inductor symbols taken from resource [19].

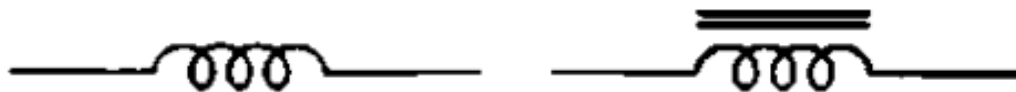

Figure 5.12 Presents an inductor from resource [19]. “Inductors. The parallel-bar symbol represents a core of magnetic material.

To conclude inductors, I would like to clarify that they're no longer used today they can be popularly found in 30/50-year-old equipment at the time of writing this thesis. However, they're still visible as they can be mostly found today in the output sections on amplifier boards this is due to them providing protection, this is confirmed and continued in resource [21], "In new audio designs, the coils have almost completely disappeared. They can still be found at amplifier outputs as an additional protection against excitation (separate amplifier output from the harmful capacitance of cables and loudspeaker system).".

5.4 Transistors

Within this project we will attempt to obtain results from a constructed artificial dummy load, we must firstly understand that in order to retrieve our output signal it must firstly be amplified, in amplifier we used transistors such as *Bipolar Junction Transistors (BJT)*, *Metal-Oxide Semiconductor Field-Effect Transistor (MOSFET)*, *Junction Field-Effect Transistor (JFET)* etc. In the below please find Figure 5.13 presenting a PNP type transistor resource [31]. This is an example that can be used in an amplifier Unitra Diora WS442 – the resource of this knowledge is taken from [32]



Figure 5.13 Presents 2N6491G ONSEMI Transistor (Source: [31])

Most commonly in amplifiers we use special low-noise transistors (BJT and JFET), this is further expanded in resource [21], "Low noise bipolar transistors or JFETs can be found in the first stage amplifiers. In the higher stages, the most common are MOSFET's or also BJTs, but with greater power.". Since transistors are not a key point in this thesis, I would like to conclude that they're commonly produced to be paired within amplifiers, this also is mentioned in [21], "They can be produced as complementary pairs". To conclude transistors, when analysing results from the output of an amplifier we must consider that each power amplifier component will have its own characteristic (hence why we pair them together) meaning that their parameters also can vary.

5.5 Audio Amplifiers and Parameters Analysis

Diving in deeper into the subject of audio measurements, this by far will be the most important subchapter of this thesis. Mentioned in this subchapter will be a set of parameters as well as their descriptions from which we will judge amplifier parameters. Without knowing such important details, we will not be able to analyse the true specification of an amplifier.

In amplifiers at best, we can receive an unclipped output, this is when the sinusoidal signal passing through our amplification systems has no cut-off regions at its peak. Therefore, sensitivity will be the maximal amount of input voltage the amplifier can undertake before the signal becomes clipped at its peaks. Of course, many amplifiers have different sensitivities. This has been previously mentioned, in electronics we don't live in a perfect theoretical world and each semiconductor has different parameters, therefore the final parameters will have some differences although, it is the same circuit. With reference to [21], this can be supported "sensitivity is the RMS value of the input voltage needed to obtain the maximum output power", continued "it changes with changes in load and frequency". In other words, if an amplifier is designed to be connected to a 4Ω speaker load and an 8Ω set of speaker loads are connected, this will result in input sensitivity differences – in practice the sound from the speakers will be quieter, at least this is the case in the forementioned 3.2 Radmor 5100 from experience.

Commonly the values of the input sensitivity are found in a popular range of 100mV to 2V, however in professional equipment this is different – therefore the division of amplifier classes provides a visible parameter difference, "Typical audio amplifier sensitivity values are from 0.1V to 2V. In professional equipment, the sensitivity is standardized and is 0.775V or, in newer systems 1.223V" as mentioned in source [21]. In conclusion, this parameter can be used to not only distinguish if the input sensitivity is correct but also have a broad overview of which type of amplifier we are dealing with.

The next topic that will be discussed in this subchapter will be the idea of noise, and how we look upon it in audio measurements. These are undesired signals that can be found on the output signal of our device, these usually cannot be predicted, “It’s impossible to predict and calculate their value at a given moment in time. They are made of many signals about different frequencies, amplitudes and origin.” as later stated in source [21]. To avoid, or even to stop enabling noise in our audio measurements we must firstly consider the different types of origins. In the below, please find a small list containing examples of such origins we could consider – these are suggested from resource [21].

- Self-generated noise,
- Thermal noise (resistive),
- Flicker caused by crystal lattice disturbances,
- Interference entering the system from the outside,
- Shot effect, resulting from the granular structure of the current,
- Recombination noise and generation of hole-electron pairs, as well as shot noise, are due to the granularity of the process.

Therefore, if we have any small components in our signal they will be blurred out and hence reducing the amount of information transmitted through our amplifier – loss in quality. Therefore, it is important to take a note of this if signal details are lost. Commonly we define the energy of the noise as P [W] whilst the *Power Spectral Density (PSD)* as p [W/Hz] as also defined in resource [21]. Not leaving anything unsaid, PSD is the amount of power per a single width of a Hz. Another important factor worth noting is white noise in our system. This sort of noise can be recognized by its distinctive hissing sound, and since it is a high frequency noise, it most certainly will matter in final audio measurements of our system. If there is a certain need, we can also reduce the amount of white noise with use of a formula, however for this formula we will need to know the PSD as well as bandwidth values. In the below, please find an equation presenting method to calculate white noise from resource [21].

$$P = p \cdot B \quad [21]$$

where

$$p = PSD \left[\frac{W}{Hz} \right]$$

$$B = \text{Bandwidth [Hz]}$$

$$B = 20000 \text{ Hz}$$

With this knowledge, we can now begin to interpret the overview of *Signal to Noise Ratio (SNR)* or just the *Signal/Noise (S/N)* factor. This is the amount of signal on the output in comparison to the amount of noise, providing us the overview that we need. These values can also be provided in terms of power [W], in the example found in the below voltage [V] has been used. Usually with SNR we should note that the larger the output result from our processed data the better the amplifier is – but we must also consider factors as previously mentioned, margin of error from program, sound card, cable attenuation and even input sensitivity issues but most certainly obtaining SNR gives us a suitable overview of what we have.

$$\frac{S}{N} = \frac{V_{signal}}{V_{noise}} \quad [21]$$

Although this provides sufficient results, most of the times we will need to see the results in a *decibel (dB)* scale format, in order to do this our measurement program automatically does this by default however if we were to also manually calculate this, we could place the equation seen in the above in a logarithmic scale, in the below please see such method.

$$\frac{S}{N} = 20 * \log\left(\frac{V_{signal}}{V_{noise}}\right) \quad [21]$$

To gradually move forward in our thesis investigation, we can also take note that in SNR – power of an amplifier SNR will be very high, and very commonly in audio measurements we refer to this as the dynamic range of our system, as stated [21], “If the measurement is performed at the maximum power of the amplifier, then the S / N becomes very large, as high as 120dB and more. This maximum value is called dynamics”.

Leaving the best for last, we have *Total Harmonic Distortion (THD)*, and it is a well-known non-linearity property in audio measurements. Whilst using an oscilloscope to view our signal, we view this signal in the time domain. Sometimes it is important to also view the signal in the frequency domain, and THD is one of those reasons. To do this we need a frequency analyser, it is a similar piece of equipment as to an oscilloscope with the difference of viewing the signal in the frequency domain rather than time.

Of course, in modern day oscilloscopes we have an option of a *Fast Fourier Transform (FFT)* to also view the frequency domain however it is slow, and usually doesn’t provide auto-math features – this however will be mentioned next. As stated in source [21], “Harmonic distortions appear within the output signal as additional components (harmonics) at frequencies that are a constant multiple of the input signal frequency”, in simpler terms these are peaks in frequency domain from which we can obtain the THD manually), as forementioned we can also use auto-math features of our measurement gear that provides this value for us automatically.

6. Plan and Design Approach

With all the necessary knowledge in the previous chapters related to components used in audio equipment as well as audio measurement related topics such as parameters and methods, we can now dive deeper into the design of our own artificial dummy load for audio measurements. In the below please find a series of subchapters consisting of mostly product research of how these loads can be constructed, what has already been made by the public or even companies and of course our own design.

6.1 Artificial Dummy Load Product Research

Throughout this section of the thesis, we will research other artificial dummy loads that are available on the market that are industry produced or *do-it-yourself* (DIY) projects – I suspect that there will be more DIY versions of the test gear in focus.

Starting with, to me, one of the most interesting artificial loads used for audio measurement I've seen. It's a Polish made artificial loads PKNW-23-01 artificial load, seen in the below Figure 6.1, that was used in factories whilst producing audio devices such as Unutra Diora. From a direct conversation with the owner of this device over electronic mail, it was determined that during the time factories that were using these specific artificial loads struggled financially and began to shut down – factory workers bought out equipment. Please see in the below part of this conversation supporting the forementioned information. [33] “I suspect that for the needs of the factories producing amplifiers and receivers, such were made, in a small number of copies. The remaining ones that weren't scrapped and employees managed to buy them back, even today there are only a few results of searching for any info about this charge.”.

With the little knowledge we know, we can already figure it was a pretty thought-out design, not only is it simple – so, but it also has one main panel where all connections are made. We also see it uses professional BNC connectors but no banana sockets, so we can not only connect our oscilloscope but also multimeters to measure the voltage (and current) flowing into the artificial load. Another big detail are the buttons in the bottom center section of the front panel, we see three sets: resistance selection, output channel selection, type of artificial load.

- Resistance selection – It's limited to only two choices, 4Ω or 8Ω ,
- Output channel selection – It's responsible for choosing, which channel is in the output BNC port enabling connection of further audio measurement equipment,
- Type of artificial load – Enables the tester to select the type of load we desire so we can either have capacitance form artificial load or resistance form artificial load, capacitive artificial loads are very good for testing the stability of the power amplifier.



Figure 6.1 Presents an Artificial Dummy Load ($4/8\Omega$) PKNW-23-01 from source: [34]

Moving on forward, in the below please find Figure 6.2 presenting the inside construction of the PKNW artificial load. We see a set of fixed carbon (non-wired) resistors, these are now vintage Soviet resistors in Polish called *Metalizowany Lakierowany Termoodporny/Metal film, Lacquer, Heat-resistant* (MŁT) made resistors that are known to be quite good. Their big down-side is that they require some time to heat up before they reach their parameters. However, these resistors are not good, at least today, for audio measurements due to the fact that they're keen to introduce noise, as supported by [35], “cheap four-strip carbon resistors, as well as metal MŁT resistors and similar, introduce noise up to ten times more than good five-strip metal resistors”. These resistors have a ceramic base on both ends, around the entire axis, that after some time crack, therefore this could be a potential design flaw in used components within this artificial audio measurement load.

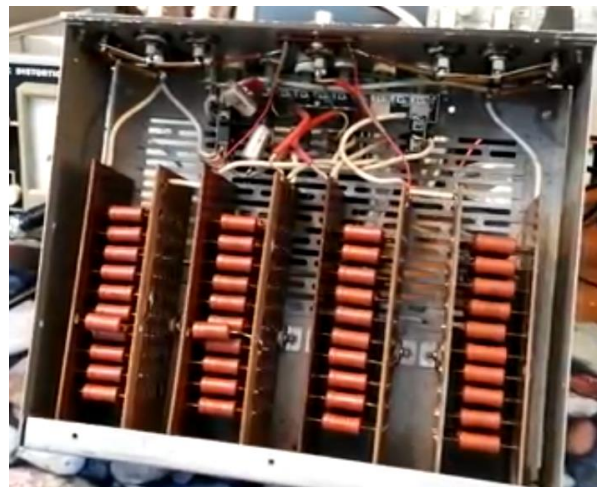

Figure 6.2 Presents Insides of Artificial Dummy Load PKNW-23-01 from source: [34]

Within the below please find Figure 6.3 presenting an artificial load designed and built by Krzysztof Popiel, from source [36]. This is a more modern, artificial load build within a plastic ABS universal housing. As seen in the forementioned figure, please see, the front panel of the device consists of a set of banana, RCA, BNC sockets and turntable selector to select appropriate resistance (4Ω or 8Ω).



Figure 6.3 Presents an Artificial Dummy Load ($4/8\Omega$) built by Krzysztof Popiel, source: [36].

In the below, please see Figure 6.4 presenting the insides of the forementioned artificial load. It's built using a set of ceramic resistors, where the previously mentioned selector knob enables the user to select between the desired resistance settings offered by the load. A very interesting approach is visible in this design, as the BNC connectors used for connection between oscilloscope and artificial load has an additional PCB from, what it can be determined to be a voltage divider – this simple technique resolves the problem of the user having to always use the appropriate oscilloscope probe to connect to the artificial load, with this in place the user simply can connect a BNC-to-BNC cable to connect the two pieces of equipment together.

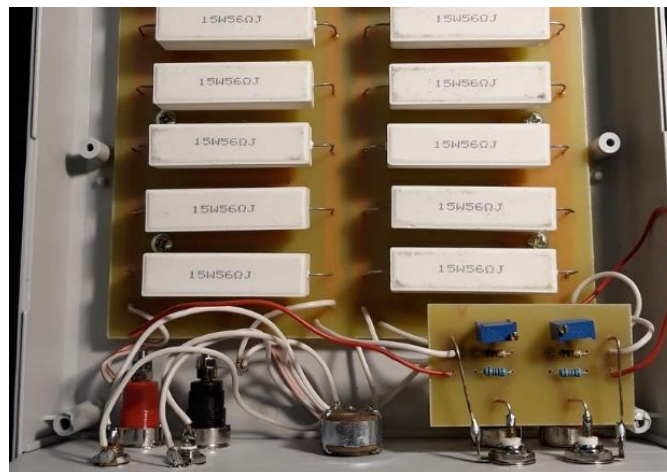

Figure 6.4 Presents Insides of Artificial Dummy Load built by Krzysztof Popiel, source: [36].

In summary, knowing these two, working, designs we can use our learned knowledge to construct our own dedicated artificial load keeping in mind the pros and cons – we must weigh the pros and cons importance scale – for example, do we want to use a metal or plastic chassis? Since, we drive towards accuracy for this thesis project, I will focus on design visible in Figure 6.3 and Figure 6.4.

6.2 Common Issues with Amplifier and Artificial Dummy Loads

In electronics nothing is ideal, we drive towards accuracy, but imperfections and issues will always come up one way or another, in this section of the thesis we will discuss potential key issues that could come up when designing artificial dummy loads.

Interference in measurement gear is quite common, this simply suggests of poor design qualities. Since the artificial dummy load that will be constructed for purpose of this thesis will also be used for personal education and renovation of vintage equipment I would like to maintain the highest quality design as I can possibly offer with what I have under hand, meaning that instead of using spring-loaded speaker terminals, such as the ones use in the PKNW-23-01 visible in Figure 6.1 and depending on the cable connected to this port we could have even a short-circuit – for example, a twisted copper wire can potentially get untwisted and touch the chassis or pick up other signals, or worse touch the other terminal due to lack of wire and socket isolation. Without correct isolated plug sockets, and cables, we risk not only damaging our equipment under test but also our test equipment therefore, to avoid this issue I would go forward and use specialistic BNC connections as well as thick banana sockets that will remove the forementioned unwanted qualities.

Since artificial loads use resistors, these can either be ceramic, wire, or even carbon, they will all generate heat. In a situation when an amplifier is tested, the load will generate a lot of heat depending on the power of the amplifier. We also should remember that this test gear is designed to take in a specific amount of power, therefore, we should always be aware of this important factor. The reason why this is so important is because the generated temperature might melt the components and even the casing, most measurement equipment today is packaged into *Acrylonitrile Butadiene Styrene (ABS)* plastic cases, which in fact are durable however might not provide as good thermal resistance.

Too high temperature will melt and deform the plastic case or even destroy the components, as all components have a dedicated amount of temperature until they begin to degrade, referred to as the *maximum operation temperature*. To support this, we could refer to wire resistors in aluminium heatsinks. For example, we will use HS100-4RF produced by ARCOL. These resistors, according to the documentation [37], have a maximal temperature of around 200 before the cooling radiator fails “At high ambient temperature dissipation derates linearly to zero at 200°C” resulting in the burning/melting of the resistor inside. Ceramic resistors also have a similar tendency, but they could also blow up inside the device, and if ventilated a lot of ceramic dust will spread amongst the workspace and air, this is due to factors such as mechanical and thermal stress as well as age. This is later confirmed by [38] who states “Ceramic capacitors (especially older types) suffer from micro-cracking. Any mechanical or thermal stress can cause them to crack internally allowing conductive parts to meet, where they should be isolated.”.

Artificial load designs, such as the one proposed by [36], might potentially require more cooling as over time visible ceramic resistors in Figure 6.4 might develop micro-cracking due to thermal stress – as forementioned from source [38]. Meaning that a fan or radiator should be used since it should dissipate heat. This also provides some level of redundancy into the design, if the fan fails the radiator will cool the component just enough so that it does not degrade/damage enabling additional time factor for the user to replace the damaged fan, this is just a realistic exemplar scenario.

As seen, in the PKNW-23-01 visible in Figure 6.1 Presents an Artificial Dummy Load ($4/8\Omega$) PKNW-23-01, the artificial load does not have a controllable user interface, due to its year of production and cheap construction. However, it does have a printed user interface on the front panel that only informs the user of the designed implementation of connection ports in the device. In summary, it is a simple design – we are missing temperature readings. The forementioned artificial load only uses switches (isostat) to regulate the selected load ($4/8\Omega$) and input channels L + R, of course this isn't bad but in today's era of technology with relays, micro-switches etc. it would be a great addition to the design. Implementing such technology, such as relays, enables some degree of automation where a microprocessors program will determine, for example, that if the temperature sensors detect a too high temperature, then automatically the device auto-shuts off and the fan proceeds to kick-into-action. Concluding, such improvements would be beneficial not only for ease of use but also taking into consideration health and safety.

In summary, discussing common issues in previously designed solutions is beneficial for future design, it is a method of trial and error. All components under stress require adequate cooling, chassis of the equipment also plays an important role to filter out any interference (unlike plastic). All of these issues will be considered in later designing stage, found in chapter 6.3.

6.3 Artificial Load Design Stage Evaluation

For this section of this thesis, we will finally plan a prototype artificial load that we will eventually produce and use. With all of the necessary knowledge about our components, properties to look out for, etc. it's safe to say that this prototype will be a somewhat clear. Of course, it is expected that issues will arise with this prototype, most likely in the construction stage – see subchapter 0.

The first step that we should consider is what we really want to have, since most up-to-date amplifiers commonly need around 8Ω of resistance at their outputs, whilst some vintage amplifiers can also require 4Ω . Therefore, to avoid issues such as input sensitivity or response to certain waveforms, as mentioned in 4.3, the user with use of an interface will manually switch between 4Ω or 8Ω when desired. Since these resistors can get hot, we will also require a cooling fan to cool the insides and avoid damaging our components inside. With use of temperature sensors, we can monitor the overall case temperature, as well as manipulate the fan to switch on whenever the temperature rises above a certain threshold. With that, there are current sensors on the market that also have humidity sensors within the module, therefore we can also the humidity in the instruments case so that our components will not get damaged. The entire thing should be controlled either by a set of buttons, however a single rotary encoder with a button switch will be fine. Personally, I would also include a clock to keep track of time when working of these devices – this is only my personal preference, as sometimes a workspace can be too cluttered to keep a clock on the desk.

Next on the list are connections, we must connect our amplifier to the device as well as our oscilloscope. The device must have safe connections that are isolated, for this I believe a standard set of 4mm banana input sockets for our output of the amplifier as well as a set of BNC coated connectors for our oscilloscope output – I suggested that they should be coated as they will wear out slower, a personal example is my vintage OS-350 polish production analog oscilloscope that requires new BNC sockets due to heavy usage over 40 years' time. We should also place a set of RCA output ports for our sound card connection, I believe the best will be placing these ports at the rear of the device as they don't really have to be connected and disconnected regularly. A potentiometer however to regulate the input to the sound card (of the amplifier output) will need to be placed at the front, therefore I think having the rotary encoder and our RMAA protective potentiometer will be quite aesthetically appealing as well as quite useful from a technical perspective. In addition to this, the potentiometer is included for RMAA software to ensure that the sound card is not over-loaded, if this occurs the DSP of our card will burn and as a result, we will lose a valuable piece of equipment for this prototype as well as thesis.

In the below, please find Figure 6.5 presenting all of the forementioned options for our front panel, the block diagram also includes the possible interface screens, however as the project evolves, I presume more will be included.

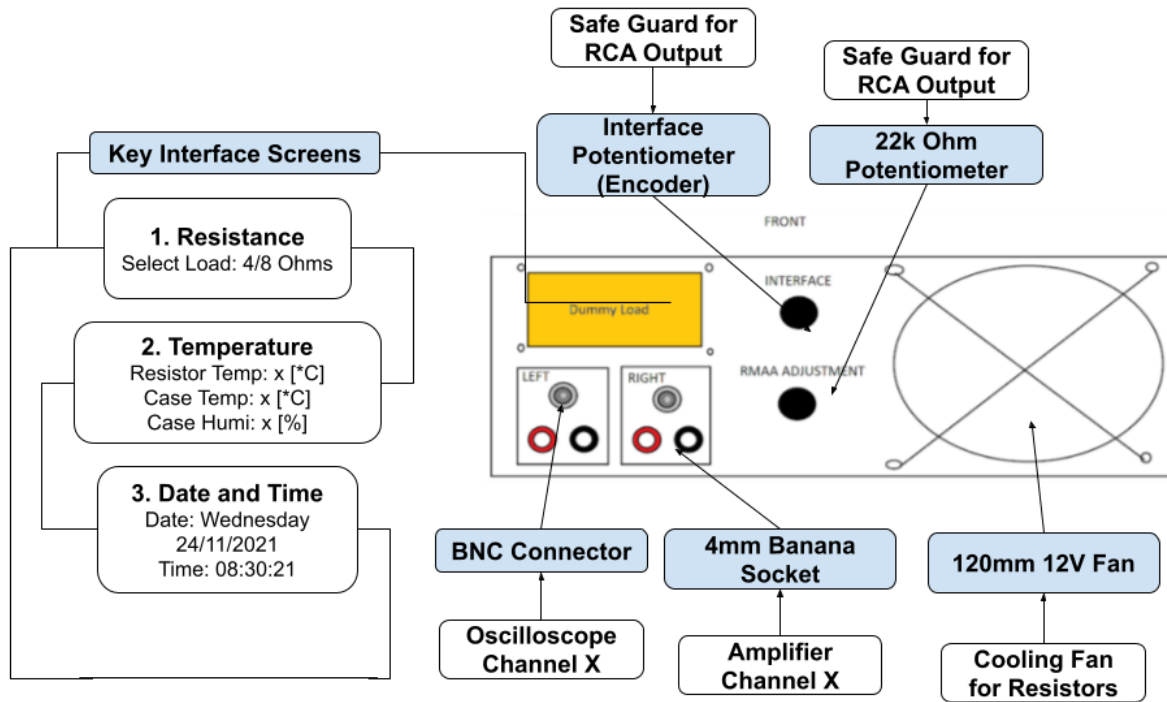

Figure 6.5 Presents a Labelled Diagram of the Final Artificial Load Design and Key Interface Screens Breakdown.

Continuing my prototype design further I've created a 3D model using Google Sketchup software [39], this model is a 1-1 version of what I wish to produce. The case that has been selected is made fully of metal, this is to reduce interference coming into the case. Constructing this 3D model enables me to plan out how I would like to space out all of the components. In the below, please find Figure 6.6, presenting the suggested design of the front panel as shown in Figure 6.5.

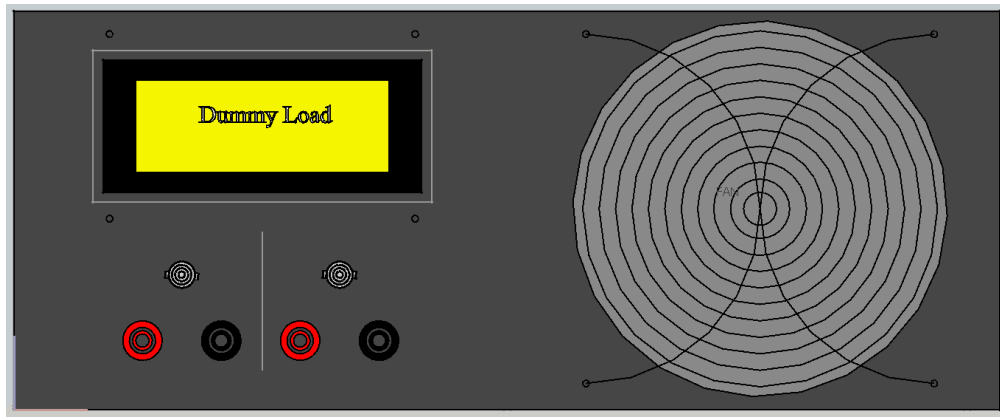

Figure 6.6 Presents a Google Sketchup Model of the Artificial Load Design with Front Panel perspective.

In the below, please find Figure 6.7, presenting the same 3D model of the artificial dummy load as in Figure 6.6 but from a top-left-side perspective, showing how these 4Ω resistors will be planned out inside of the casing. The resistors will be connected in series so $4\Omega + 4\Omega = 8\Omega$ and will be wired through a relay controlled by the Arduino controller.

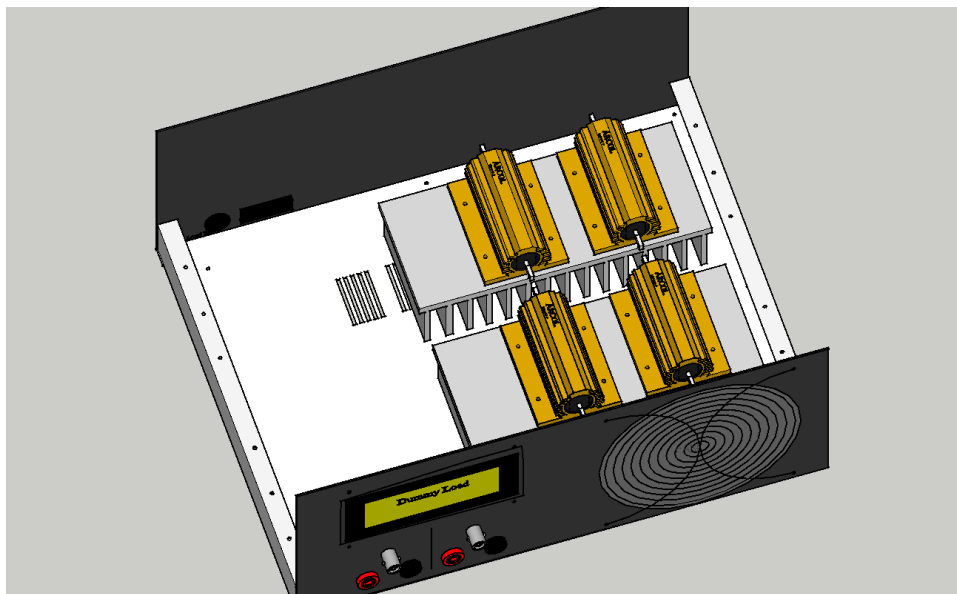

Figure 6.7 Presents a Google Sketchup Model of the Artificial Load Design Top View with Front Panel Perspective.

All designs will have their positive and negative sides, often referred to as pros and cons. We will break down the pros and cons of our design, to show that we're aware of this and potentially if there would be any changes to the design. In the next chapter (Design Technical Implementation) we will start to develop our design and generating such list would be beneficial to avoid surprises. I believe that noticing the cons of a design is a positive approach to designing a well-made piece of gear – our artificial dummy load.

The pros of the final design:

- Design has an all-metal casing and chassis as a result blocking any interferences going into our measurement circuits,
- Design has a big (12mm) fan that provides cooling to the passive resistive components – in our design these are the wire resistors in the aluminium casing,
- Front panel uses professional connection solutions, for example banana sockets instead of spring-loaded wire sockets and BNC ports for direct Oscilloscope connection without using a probe,
- Due to the materials used such as, the metal chassis and large aluminium heatsinks, the artificial dummy load is quite heavy, which in a way is a good thing as I've found that equipment shouldn't be weightless as it would move around when unwanted – for example, when plugging in banana or BNC cables into the front panel.

The cons of the final design:

- Missing another BNC connector to directly connect multimeter to measure the voltage flowing into the artificial load,
- Using an all-metal big case results in the measurement gear being relatively heavy, which as a result makes the artificial load not very mobile, plastic would be lighter if the measurement gear would be commonly moved from one place to another,
- The artificial load is designed to be supplied with power directly from an impulse power supply, this is a drawback since the impulse power supply could potentially add interference/noise... Therefore, a linear power supply would be more beneficial for this in the future,
- The *control board* (Arduino Controller), used in this design is very limited as it only has one processor core and no other sub tasks can be done, therefore making the GUI limited in its design – for example, when gathering data on temperature inside the case, we cannot at the same time turn on the fan since we must wait until we gather the temperature data first,
- With the all-metal case use it makes the artificial load very expensive, since metal costs more than ABS plastic, in the above please find Table 6.1 providing calculated and converted raw material prices confirming the forementioned price difference.

Table 6.1

Presents the USD Price Comparison between Aluminium and ABS Raw Materials as of 7.1.2022.

Material	Pricing
Aluminium	3.23 USD/KG [40]
ABS	1.17 USD/KG [41]

7. Design Technical Implementation

7.1 Production Plan

With focus on connections in the entire prototype, in the below please find Figure 7.1 that presents the schematic diagram of how I will connect all of the elements so that the artificial load itself will operate. As seen, I have firstly taken into consideration the relays as these in our circuit will enable R_3 and R_4 into the circuit, as a result we will obtain a resistance of 8Ω at request.

Next, I have ensured that we have an output line to our sound card through our protective potentiometer. The last step was to continue the connection to a designed voltage divider that will enable a direct BNC-BNC connection between our circuit and oscilloscope without using specialistic probes – reduces chance of wrong connection as well as clutter on the workspace.

ARTIFICIAL LOAD SCHEMATIC

- $R_1 = R_2 = R_3 = R_4 = 4\Omega$ $T_{\text{OK}} = 1\%$
 $P_{\text{max}} = 100\text{W}$
- $R_5 = R_6 = 22\text{k}\Omega$ $T_{\text{OK}} = 2\%$
 $P_{\text{max}} = 63\text{mW}$
- $R_7 = R_8 = 10\text{k}\Omega$ $T_{\text{OK}} = 1\%$
 $P_{\text{max}} = 0.6\text{W}$
- $R_9 = R_{10} = 900\Omega$ $T_{\text{OK}} = 1\%$
 $P_{\text{max}} = 0.6\text{W}$
- $R_{11} = R_{12} = 200\Omega$ $T_{\text{OK}} = 10\%$
 $P_{\text{max}} = 500\text{mW}$

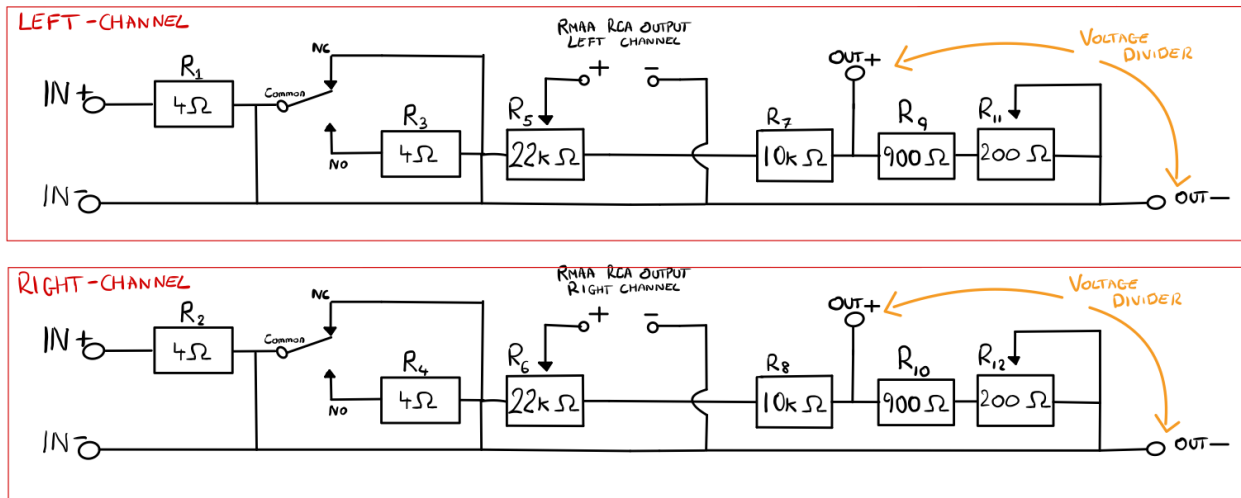

NC = Normally Closed
NO = Normally Open

Figure 7.1 Presents the Artificial Load Schema.

Please note that R₁₁ and R₁₂ are 200 potentiometers that will aid in adjusting the correct output voltage of our potentiometer.

Expanding the voltage divider circuit, it is a straightforward standard design [19], to obtain the necessary desired parameters I wanted my voltage divider to in fact act as a probe, therefore at the output I desired to have 1V when the voltage source was at 10V. With 1% resistors in place and a potentiometer to regulate the output, I can accurately complete this step and obtain our desired effect. In the below please see Figure 7.2 containing all of the math that enabled me to know which potentiometer I could use.

VOLTAGE DIVIDER

$$V_{OUT} = \frac{V_S \cdot R_2}{(R_1 + R_2)}$$

where:
 $V_S = \text{Voltage Source}$
 $R_1 = 10k$
 $R_2 = ?$
 $V_{OUT} = \text{Voltage Output}$

$$\Rightarrow 1 = \frac{10 \cdot R_2}{10k + R_2} \Rightarrow 10k + R_2 = 10 \cdot R_2 \Rightarrow R_2 = 10 \cdot R_2 - 10k \Rightarrow -9R_2 = -10k$$

$$\Rightarrow \frac{-9R_2}{-9} = \frac{-10k}{-9} \Rightarrow R_2 = \frac{10k}{9} = 1111,111 \Rightarrow R_2 - 900 = \underline{211,111 \Omega}$$

Figure 7.2 Presents Output Stage Voltage Divider Theoretical R11 and R12 (R2) Calculations.

In conclusion, I've not only been able to plan out my circuit routing, but also which type of potentiometer should be used for regulating this voltage divider, from the calculations 211.111Ω is our desired resistance therefore a standard 20% tolerance potentiometer will enable us a range of extra 40Ω of flexibility.

For the next part we also must have a plan of the controller schematic, therefore knowing how we will connect all of the necessary modules together will enable us to plan out their positioning inside the case. In the below please find Figure 7.3 presenting the forementioned schematic.

For this project, I will be using an Arduino Mega 2560, it may not be the best device for this project, however since this is only a prototype it is enough. For this project, I will use a provided impulse 9V power supply. All of the modules share the same line, however, to reduce strain on the small MOSFET transistor powering the 5V on the Arduino controller itself I've decided to power them directly from the DC-DC Buck converter since it can handle a higher amount of current.

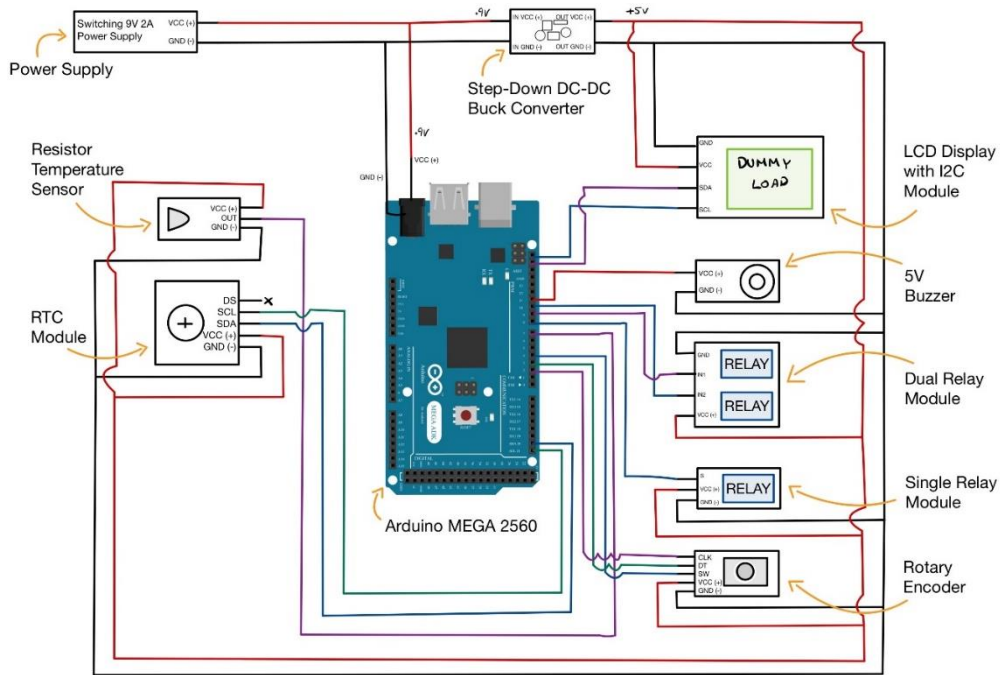

Figure 7.3 Presents a Labelled Arduino Module Connection Schema used for Artificial Load.

Since the above schemas are quite detailed, please find Figure 7.4 a simplified overview of the artificial load project. Most of this diagram presents the available features of this load.

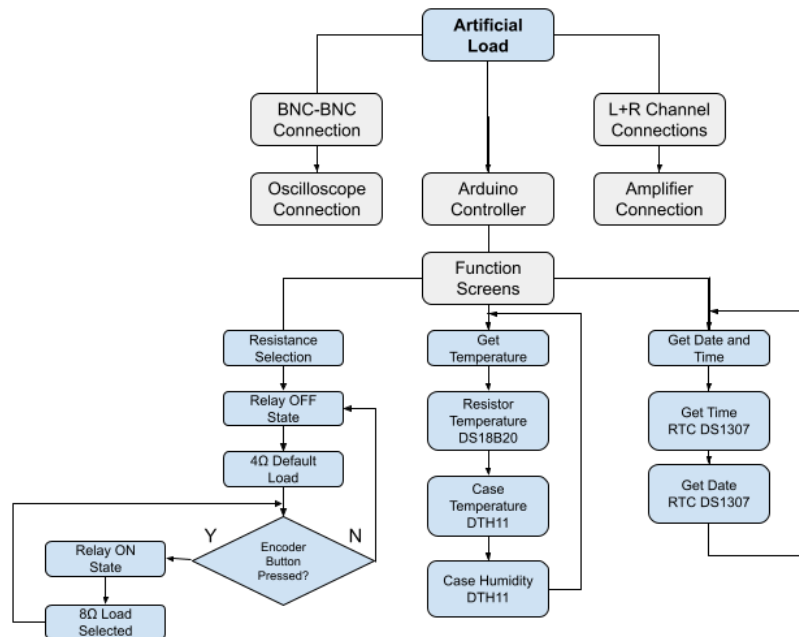

Figure 7.4 Presents a block diagram of Artificial Load Overview





Concluding this subchapter, we were able to present a planned overview of what we would like to see in terms of schematics as well as the design and placement of specific components.

Artificial Load Construction and Production Stage

Within this subchapter, we will go through certain steps made during the production of this artificial load prototype. Therefore, in the below, please find Table 7.1 presenting steps taken in order to complete the artificial load prototype.

Table 7.1

Presents a set of construction as well as production steps taken to complete the artificial load prototype.

	
<p>Starting the project off I firstly began with preparations of the radiators. These are recycled radiators from a Radmor 5412 receiver, they have been sanded so that the surface is straight.</p>	<p>For the next work on the radiators, after sanding I begun to drill and tap the necessary holes for the 100W resistors to be mounted in place.</p>
	
<p>Before mounting the previously mentioned resistors, I wanted to ensure good thermal contact. Therefore, using <i>Isopropyl Alcohol (IPA)</i> I cleaned the surface and applied thermal grease with silver components to enable good thermal conductivity.</p>	<p>After all of these steps were done all of the resistors have been mounted onto the radiator blocks.</p>



For the next part, as per design, I wanted to map out all of the holes and cuts needed to be made, this has been done using precise callipers, a metal ruler and a laser cut metal scratch tool.



I have firstly started with the BNC, Banana, and potentiometer holes, these were the most difficult due to wait time. I have changed the drill bit size every hole; however, it was quite hot after usage.

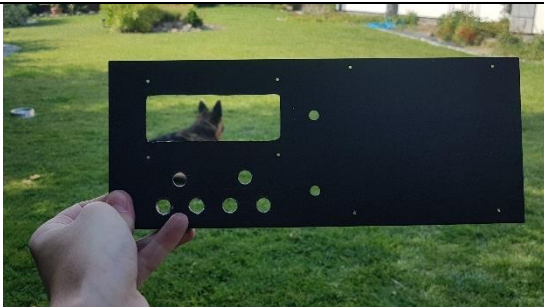

All of the holes have been cut, except from the largest fan hole. This is because I've run into a small problem of not having any more cutting discs. Therefore, I needed to resupply myself in a set of these.







With cutting discs resupplied using the Dremel tool, I've continued to cut out the circular hole for the fan. I have firstly drilled small holes around the radius and then cut the remaining metal with the disc. To finish, I have sanded the edges.

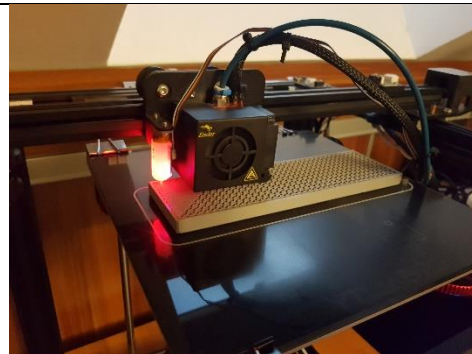

Due to a lot of mechanical work, I've scratched up the front panel – to fit this I cleaned, primed, and painted using black semi-matt paint.

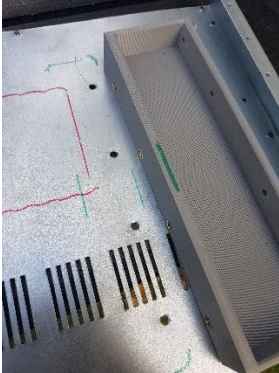
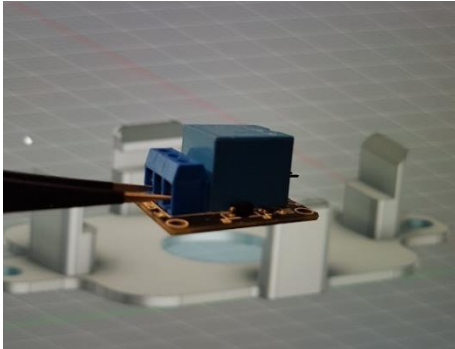
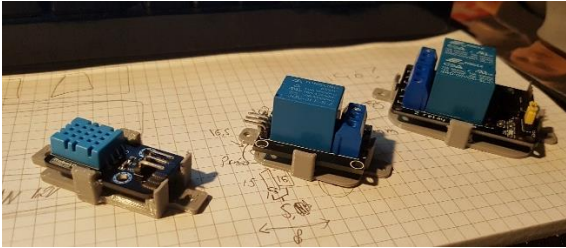

In order to mount the radiator with our resistors, I've designed and 3D printed a special plastic mount using PET-G filament, enabling higher

	<p>thermal properties. ABS was not used due to printer limitations and lacking gear.</p>
	
<p>I needed to mount the printed mounts onto the chassis, therefore I inserted brass screw inserts using a soldering iron tip.</p>	<p>Having all of the brass inserts melted into the plastic, it was time to mount it onto the chassis.</p>
	
<p>To match the made holes, I've attempted to trace out and measure the correct locations of all inserts.</p>	<p>In order to mount the relays, I've designed and 3D printed from PET-G clip-in bumpers for our components.</p>
	
<p>All of the clips have been designed and are ready to be mounted onto the chassis.</p>	<p>All of the components needed have been mounted inside the case, with now only the wiring was left.</p>

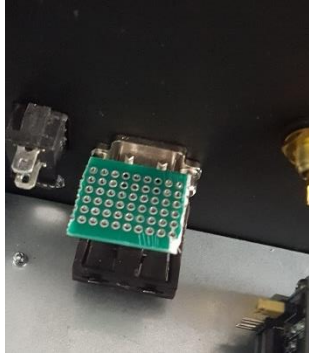

Using a small piece of a prototype PCB, I have mounted and connected the USB connection for Arduino controlled to reprogram when needed.

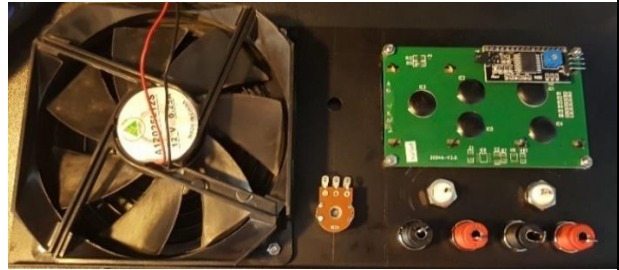

Having drilled the panel, all of the components have been mounted and are ready to be assembled.

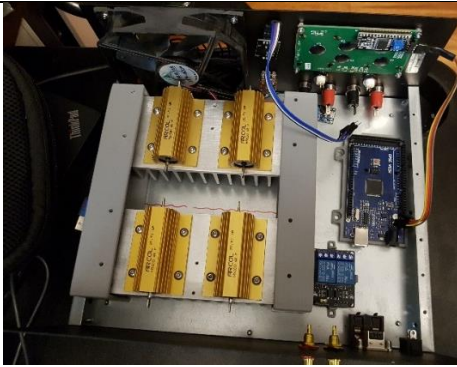

Using previously printed mounts, most of the components have been mounted.

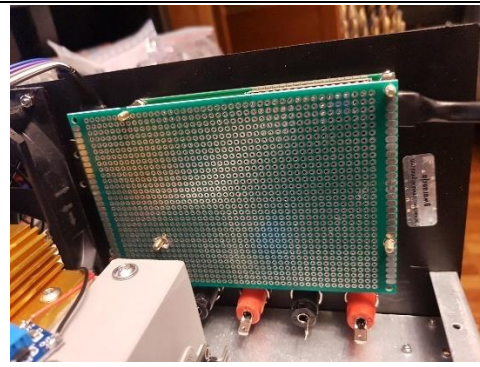

I have mounted this shield from a prototype PCB. This PCB, when having all connections made, will be use as the voltage divider board for the oscilloscope.



This is the view of the complete front panel.



This is another view of the completed front panel with powered on *liquid crystal display (LCD)*.

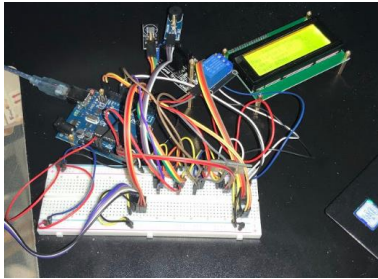

Before I could connect any of the sensors and Arduino parts, I have firstly written a program and tested it using a prototype board.

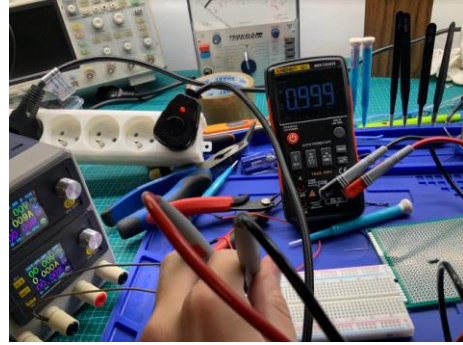

Having soldered the voltage divider, I set at 10V of input the 1V output as seen on the multimeter.

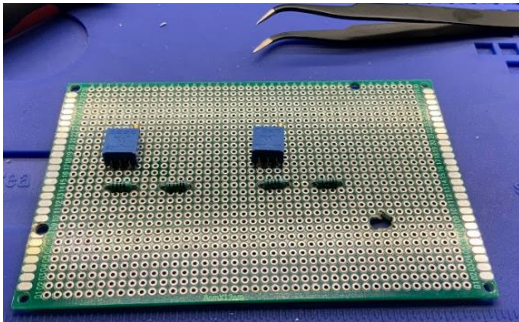

This is how the voltage divider looks like, the input will enter the blue potentiometer whilst the BNC output wire will be between the two 1% resistors.

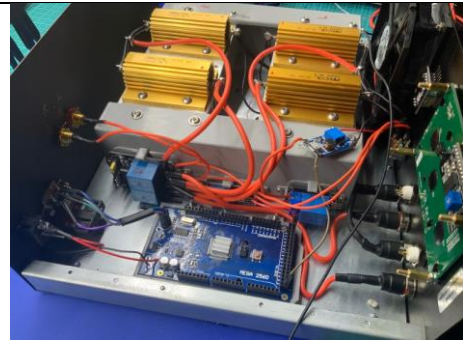

I have wired the banana cables to the resistors as well as the resistor connections to the relays, so that switching between resistance would be possible.

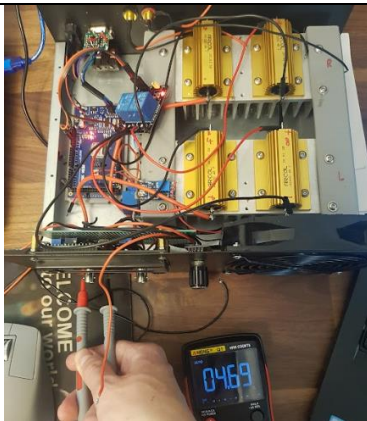

To test if our resistance can be switched using a multimeter, I have switched one portion to 4Ω input.

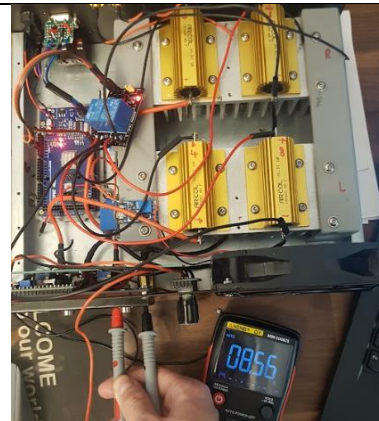

To test if our resistance can be switched using a multimeter, I have switched the other portion to 8Ω input.

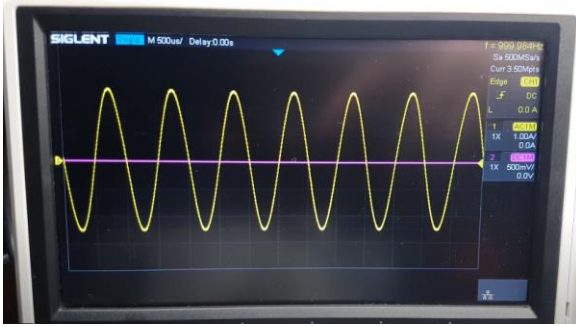

To test the correct functionality of the artificial load, I have connected it to a function generator and tested if at 1kHz input frequency we can obtain the correct measurements on the output using the oscilloscope – which we can, see top right screen of oscilloscope.

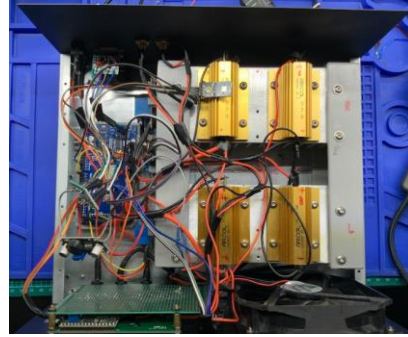

For the pre-last step, I have soldered all of the remaining components, added a DC buck converter to restrain the Arduino MOSFET from all of the power deliver load to components.



This is the final look at the working design, this prototype of an artificial load was successful, however some problems came to light. This simply proves how important prototypes really are.

7.2 Setting up the Testbed (Using Audio Card, Amplifier, Computer, Oscilloscope to test an Amplifier Circuit)

Within this small subchapter I would like to present two possible scenarios which I have in plan to use the artificial load for, the first is connecting the artificial load directly to the sound card and analysing the results through that, whilst the other concept scenario is using the oscilloscope itself directly.

In the below please find Figure 7.5 presenting a simple block diagram connection loop of the *Right Mark Audio Analyser* (RMAA) computer software using a sound card to transmit and receive appropriate signals. We see that the sound card is playing in two fields, as the sender and receiver – the input of the sound card (output) is connected to the amplifier, lets say just as a function generator, the amplified signal then travels through the appropriate circuit path of the artificial load and travels back to the output of the load (to input of the sound card – captures the retrieved audio signals).

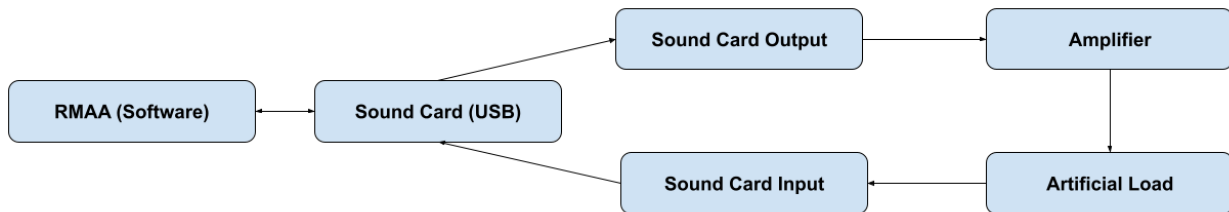

Figure 7.5 Presents Basic Block Diagram of Setup Needed for Testing Using RMAA Software.

Continuing forward in the below please find Figure 7.6 presenting a simple block diagram connection between the function generator (our input signal), to the oscilloscope through our amplified artificial load line.



Figure 7.6 Presents Basic Block Diagram of Setup Needed for Testing Using Oscilloscope

In conclusion, we have two separate block diagram concept connections to our artificial load – I believe that this prototype can be further expanded directly into the computer itself via. *Universal Serial Bus (USB)* port, from which we can infer that the design could potentially have a built-in sound card rather than using an external one.

7.3 Hardware and Software Measurement Techniques and Analysis Evaluation

For this subchapter, we will divide into two different types of evaluation measurement techniques, one of which is the hardware analysis – this is analysis based on measurement gear such as an oscilloscope. Whilst the other is software analysis, this being the previously mentioned RMAA computer program.

For the hardware analysis part of this subchapter, we will focus on hooking up the artificial load to our oscilloscope. For the load we have connected an amplifier, in this case Technics SU-VX470, having passed through it a sinusoidal waveform through the AUX port we were able to obtain the output waveform. In the below please find Figure 7.7 presenting the previously mentioned waveform. As we can see, the two waveforms (left and right) have some differences between them – this is normal. We can also see that we have no clipping, meaning that our waveforms are not cut off anywhere, suggesting the correct functionality of our amplifier.

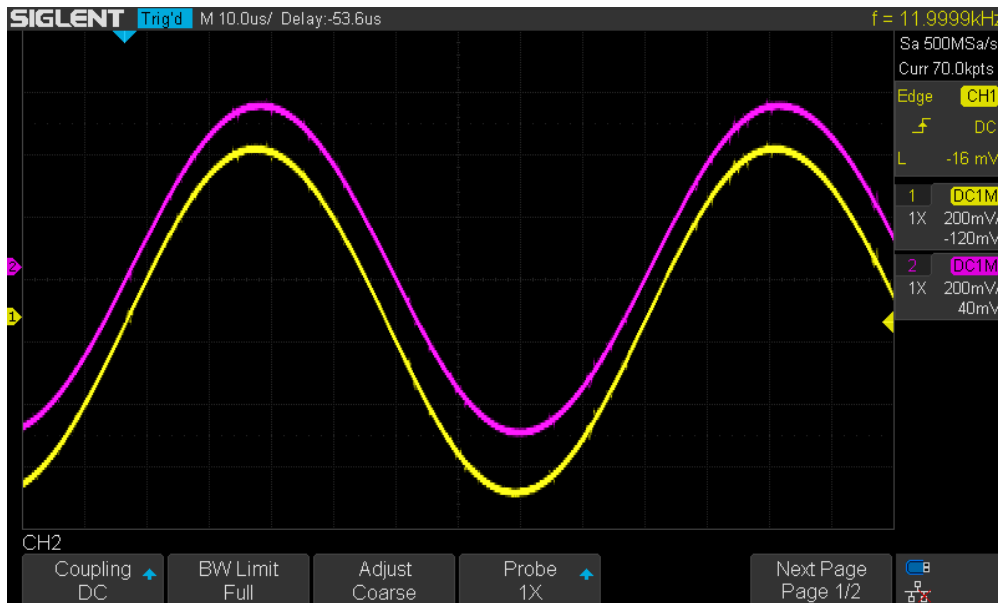

Figure 7.7 Input Signal of 12kHz Function Generator at 4 Ohms Resistance Set on Artificial Load

However, as all good things go, we must also find issues and in this case the main concern was visible interference after moving around cables in the artificial load. I've found that when the LCD is connected from time-to-time interference is visible, I've tracked the issue down and found that the problem is in the Arduino controller – it has no filtering of its input output ports and since our relays are of low quality they are passing through this interference. Resolution of this problem is to use better relays or apply filtering of interference from powering the display. In fact, the root of the cause is the power supply, as when closed inspected we can see small impulse like points.

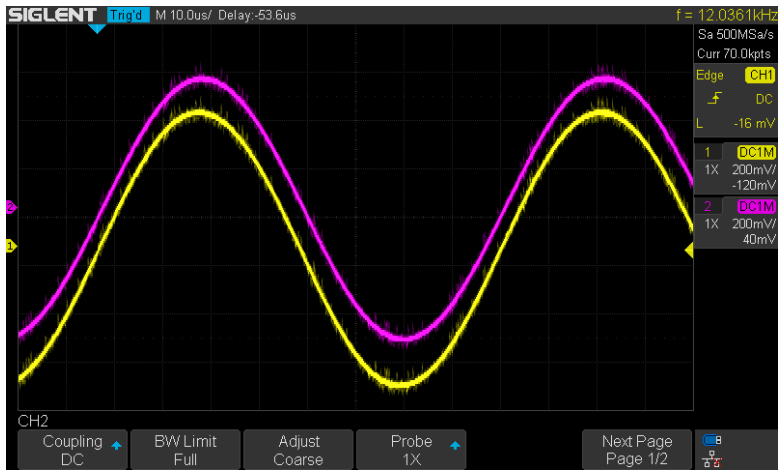

Figure 7.8 When LCD is Drawing Current, we Observe Interference.

The next part of our analysis technique is the software part, this'll be the use of RMAA software. This is a free software, that essentially provides fairly accurate results. However, it requires calibration before any measurement is conducted. Therefore, in the below please see Figure 7.9 presenting the calibration stage, whereby adjusting the 22 kΩ potentiometer we're able to not over-drive the sound card's DSP (to avoid damaging it) as well as adjusting the maximal level the program suggests.

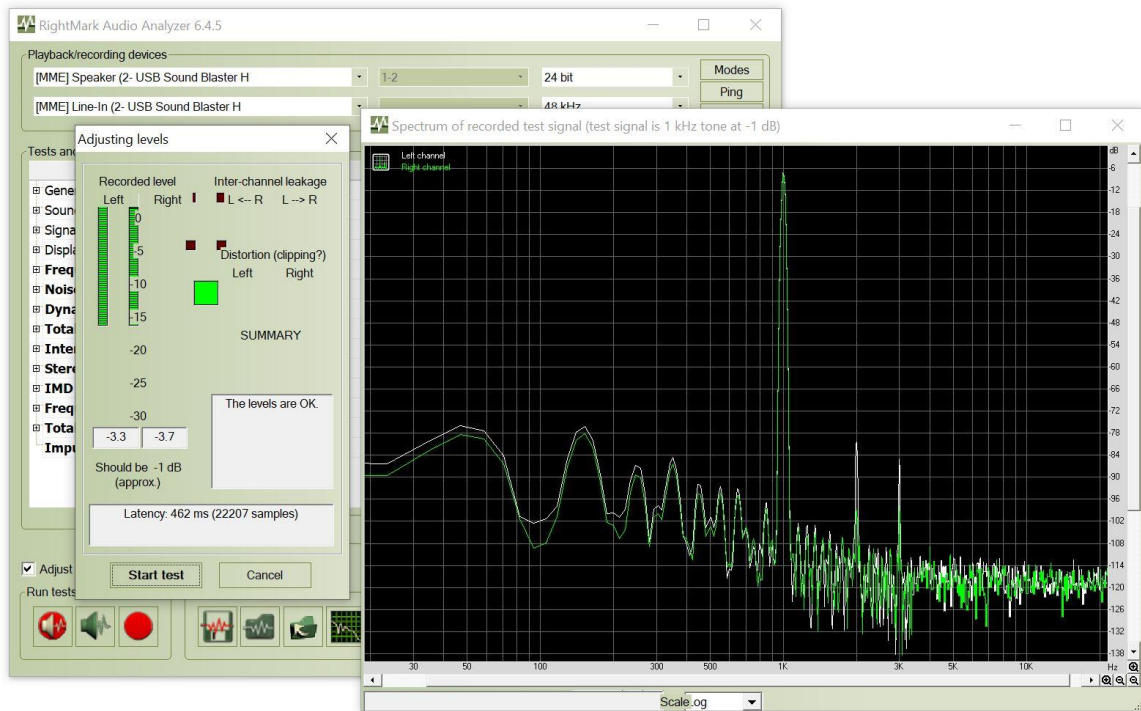

Figure 7.9 Right Mark Audio Analyser - Good Results.

Having connect the previously mentioned amplifier, we have run the simulation as seen in Figure 7.9 in the above, the “Start Test” button was pressed. Therefore, in the below please see Figure 7.10, a summary of this test as well as my observations and final conclusions.

Frequency response (from 40 Hz to 15 kHz), dB	+0.12, -0.17	Very good
Noise level, dB (A)	-82.9	Good
Dynamic range, dB (A)	83.0	Good
THD, %	0.011	Good
THD + Noise, dB (A)	-72.1	Average
IMD + Noise, %	0.074	Good
Stereo crosstalk, dB	-39.9	Very poor
IMD at 10 kHz, %	0.018	Very good
General performance		Good

Figure 7.10 RMAA Final Results

As visible in Figure 7.10 we can observe our results of such test. This test took around 5 minutes of waiting time, and we can already see the positive results on the far-right column. We see that some parameters such as THD with the noise factors are not so great. In general, the lower the THD the better, the best would be ideally at 0.01%. I believe that this is the results of not only the poor performance of the amplifier but also the build of the prototype, this is later discussed in chapter 7.4. We also have a lot of stereo cross talk, as seen it is marked a very poor however this is due to the construction of the amplifier since it has only one power amplifier divided into two channels, a better resolution would be to use two amplifiers meaning one per channel (left + right) but of course this is a factor of class of the amplifier. We also can notice that the noise as well as frequency response is quite good. In conclusion, this shows that the RMAA test through our prototype artificial load works.

7.4 Improvements to Design in the Future

Within this section of the thesis, I'll determine the possible improvements that could be made in my project in the future.

Firstly, I would like to expand on the possible power supply related improvements that I would like to improve. The power supply used in powering the Arduino controller board is not very noise-proof and when hooking up the oscilloscope to the artificial load we can see some noise coming from the impulse power supply. A resolution of this problem would be to fit an AC network filter, to filter out any unwanted noise or interference generated in our grid, as well as a dedicated linear power supply (transformer). In the below please see, Figure 7.11, the fore mentioned AC network filter that can be mounted into the case of the artificial load.



Figure 7.11 Presents an AC supply socket with filter (3A, 250VAC), model FYB03T1 produced by YUNPEN ELECTRONIC. As stated in manufacturers documentation, [42], “General purpose filter with IEC connector providing effective line-to-ground noise up to 15 amp”.

Due to the construction of the Arduino controller as well as the components such as rotary encoders, relays etc. are of poor quality – this is somewhat related to the price of these components as they were cheap. Unfortunately, the relationship of price and quality is visible here, the more the element costs the more accurate/proper made it'll be – for example, please see Figure 7.8 showing a power filtering related issue, where the LCD when drawing current from the onboard Arduino MOSFET (5V) it generates a lot of noise and interference to our output signal. This might be the issue that we're using shared power from the same impulse power supply, as forementioned.

The Arduino controller used in this project is cheaply made, therefore I do not expect it to perform as a professional-grade measurement instrument but can be used for amateur testing. A resolution of this issue as well as for other generated interferences from other elements such as the rotary encoder or relays, would be shielding elements please see Figure 3.2 in, which (on the last from right PCB) we see a sensitive radio head unit that is shielded with thin aluminium – for example, preventing any interferences from entering the coils, as mentioned in subchapter 5.3 these store energy in magnetic fields.

Continuing the topic of power supply in this project, another potential improvement is in using a different controller board. In my opinion, the Arduino is a great prototyping controller, that enables to see what in fact we could require from the project. Therefore, it would come at a great advantage, designing a custom controller board for this piece of measurement equipment would be more beneficial, since we can design all of the components such as the relays, thermal sensors etc. would be placed onto one PCB instead of separating it into different components – as that introduces clutter in cables used, the less we use the less noise we could potentially retract from the measurements.

The controller upgrade, as forementioned, would be a very beneficial improvement to the artificial load and with this a standby mode can be included into the project. Whenever the standby mode is turned off, a relay will simply turn on all of the related circuits delivering power to our systems such as the controller board. Using a different processor that can handle multicore processing, so that we can perform various tasks at one time, enabling us to for example monitor the temperature and deliver date and time data from the RTC – instead of doing it sequentially so, first the temperature sensor data is gathered and only then the RTC data is delivered. Designing a new controller board would also enable us to design a separate board for the LCD screen as well as the encoder, in the future I would like to add two things into this design. These changes are buttons with rotary encoder to ease navigation/selecting parameters and an additional BNC output to connect external devices such as an analogy power meter etc.

The chassis of the artificial load is all metal, which seems like a big advantage excluding the price factor. However, the front panel will require some modifications. In the forementioned above controller board upgrade it has been mentioned that buttons and an additional BNC output could be added into the board, additional holes need to be made. During the creation of the front panel, I have used very mechanically invasive processes, such as using drill bits to make holes and mini tools to create larger holes, such as for the LCD or fan. As a result, the front panel is a little bent this is visible upon close inspection however is only a constructional aesthetic factor, as the measurements taken from the device are rather unaffected. Next time I would like to use laser cutting technology to cut out necessary holes in the front panel in order to receive strong straight cuts all throughout the panel. Using this technology could also enable engraving text into the metal, ensuring in labelling of the front panel to ease usage of the measurement instrument.

Whilst discussing the chassis, it can be mentioned that the radiator mounts, used in the design, are made of plastic in order to separate the metal radiator plates from the metal casing of the artificial load in order to minimise the amount of transmitted interference throughout the case. However, this is mentioned as an improvement since for all plastic elements I have used PET-G 3D printer filament. PET-G filament has a higher melting point than PLA filament, this is also supported by [43] “Melting Point: 190°F” and “PETG is heat resistant with a glass transition temperature of about 80 degrees Celsius. It has a higher melting point than PLA which makes storage of completed prints last longer over time”. However, the best in this case would be ABS plastic. Due to constraints of the used 3D printer such mounts couldn’t have been printed using ABS plastic but in the future, it would be a great improvement to use such mounts in the design to provide higher maximal thermal properties. With reference to [44], “Compared with PLA, PETG is more durable, scratch-resistant and more flexible.” We can infer that for the time being, PET-G seems to be a good temporary measure.

In summary, although the artificial load constructed is a form of prototype, the improvements seem to be quite vast. With knowledge from all chapters, especially this subchapter, we now have a perspective of how much time, finances, and brainpower it takes to construct a really reliable pieces of test great for audio measurements. In the future, I would most likely benefit from this thesis to later improve my design.

8. Conclusion

Concluding this thesis, I would like to firstly comment that having performed such detailed multi-source research within this thesis enabled me to explore as well as learn audio measurement techniques and different types of important parameters. Therefore, I believe that the project concept as well as final details, measurements and results were incredibly successful.

Within the first chapter 3, we were able to discuss and figure out what amplifiers are and how important they are for this thesis. We have learned that these devices are very sensitive many different factors such as temperature, interference as well as state and quality of components used inside. I believe that we can state with some confidence that these devices must be precisely tuned just as a piano, however in this case with use of all sorts of necessary electrical apparatus e.g., oscilloscope, multimeter etc. During this chapter we have also expanded on how we can obtain acoustical measurements and audio measurements with use of artificial loads, this has been discussed in such manner to create a comparison between the two techniques.

With amplifier construction being quite significant within this project as well as somewhat understanding how they operate; we were able to understand how our audio signal is amplified as well as how we can hear this produced signal. All this can be found in the next chapter 4 within which we also discussed how we could potentially test the correctness of the used software for our audio measurements with our artificial load.

Having the broad overview already, we also needed to explore how certain semiconductor components operate and function and in chapter 5, we needed to expand on this as without this knowledge we wouldn't be able to determine the parameters as well as types of components needed for completions of this artificial load prototypes. However, the key focus of these explored topics, the most important of them all was the research of the types of audio parameters. Using the necessary resources, I have gained a higher level of knowledge and understand of these parameters, as we must remember when performing measurements, we cannot just expect to receive all of the results we want with the "plug-and-play" approach. Therefore, we must take into consideration that some degree of patience will be required for measurements, as not all things can be gathered by a piece of software or hardware.

Aside from the main idea of this thesis, I have personally also developed some degree of new skills such as working with metal and new types of tools as can be found in chapter 6 and 7. Furthermore, we have also explored the approach of planning such prototype, doing so, we have gained and developed a perspective of how much work is required to produce something providing positive results. Regarding the results, I believe that if we were to exclude the fact that this project work was a prototype the obtained final measurements and results were quite good and positive, taken into consideration how much time was dedicated for research, planning and production of this device – regarding the measurements made on the device of course we should be open to improvement. Within this project of the thesis, we see that there is plenty of room for improvement, such as the production of the device such as cutting and placing the components as well as the consultation of the device itself since some degree of interference has been visible in our results and with some time and more brain power, I believe that this can be greatly improved.

Therefore, to conclude this thesis as well as project with all of the gained knowledge of how certain elements work, as well as how certain things can be tested, explored further, and improve I believe that this is very beneficial and a good step forward to designing a fully working device – so from prototype to final piece. Overall, I claim this prototype as a significant success.

9. References

- [1] Kraft, "AVT Korporacja Audio Forum," 21 September 2017. [Online]. Available: <https://forum.audio.com.pl/topic/47337-sieciowe-amplitunery-i-wzmacniacze-stereo/>.
- [2] M. L. Daniel Ek, "Spotify," 2006. [Online]. Available: <https://www.spotify.com/pl/>.
- [3] P. Shaman, "o Unitrze," 9 November 2009. [Online]. Available: https://unitraklub.pl/o_unitrze.
- [4] TELPOD, "Polish Semiconductor Manufacturer," TELPOD, [Online]. Available: <https://www.telpod.pl/>.
- [5] P. Shaman, "Opis," 29 March 2015. [Online]. Available: <https://unitraklub.pl/opis/407>.
- [6] P. S. L. Patrick N. Breysse, "JHSPHOPEN," 2006. [Online]. Available: ocw.jhsphe.edu/courses/PrinciplesIndustrialHygiene/PDFs/Lecture6.pdf.
- [7] M. Leśniewicz, Home Audio Systems (Domowe System Audio), Legionowo: BTC, 2014.
- [8] iXBT.com, "Latest Version," 21 07 2018. [Online]. Available: <https://audio.rightmark.org/>.
- [9] A. G. F. D. Purves D, "The Audible Spectrum," in *Neuroscience. 2nd edition*, Sunderland, Sinauer Associates NBK10924, 2001.
- [10] S. W. Smith, The Scientist and Engineer's Guide to Digital Signal Processing, 1997.
- [11] W. Rościszewski-Wojtanowski, "Design and Apply Analog Filters," Poznań, 2020.
- [12] "Transistor Design," Backyard Brains, 2009. [Online]. Available: <https://backyardbrains.com/experiments/transistorDesign>.
- [13] W. Storr, "Common Emitter Amplifier," Electronics Tutorials, December 2021. [Online]. Available: https://www.electronics-tutorials.ws/amplifier/amp_2.html.
- [14] W. Storr, "Amplifier Classes," Electronics Tutorials, November 2020. [Online]. Available: <https://www.electronics-tutorials.ws/amplifier/amplifier-classes.html>.

- [15] J. Roberts, "Audio Power Amplifier Fundamentals," rocketroberts, 7 4 2016. [Online]. Available: <http://www.rocketroberts.com/techart/amp.htm>.
- [16] J. Didden, "LA Autoranger," [Online]. Available: <https://linearaudio.nl/la-autoranger>.
- [17] FeelElec, "GoTronik," FeelElec, 5 2019. [Online]. Available: <http://gotronik.pl/images/FY6900%20Series%20Users%20Manual%20V1.0.pdf>.
- [18] "Keuwlsoft Function Generator," 20 6 2020. [Online]. Available: <https://play.google.com/store/apps/details?id=com.keuwl.functiongenerator&hl=pl&gl=US>.
- [19] W. H. Paul Horowitz, The Art of Electronics, Third Edition, New York: Press Syndicate, 2015.
- [20] "Electronic Components - Resistors," 2006. [Online]. Available: https://www.electronics-notes.com/articles/electronic_components/resistors/resistor-types.php.
- [21] J. Gołaszewski, Wzmacniacze Audio Poradnik Konstruktora, Legionowo: BTC, 2008.
- [22] a. w. t. e. s. o. A. D. Hank Zumbahlen, Linear Circuit Design Handbook, Norwood: Newnes; 1st edition, 2008.
- [23] Kemet, "Introduction to Capacitor," 2013. [Online]. Available: https://www.mouser.cn/pdfDocs/eb1001_what_is_a_capacitor.pdf.
- [24] [Online]. Available: <http://www.miflex.com.pl/>.
- [25] EPCI, 29 12 2021. [Online]. Available: <https://passive-components.eu/why-low-esr-matters-in-capacitor-design/>.
- [26] EPCI, 5 1 2022. [Online]. Available: <https://passive-components.eu/ripple-current-and-its-effects-on-the-performance-of-capacitors/>.
- [27] Knowles Capacitors, Norwich, U.K., "The Methods and Problems of Capacitor ESR Measurement," *Microwave Journal*, p. 8, 2016.
- [28] Nichicon, "ALUMINUM ELECTROLYTIC CAPACITORS," [Online]. Available: https://pl.mouser.com/datasheet/2/293/e_ukz-1513448.pdf.

- [29] W. Elektronik, "Electronics Components," [Online]. Available: https://www.welonline.com/web/en/electronic_components/news_pbs/blog_pbcm/blog_detail-worldofelectronics_105535.php.
- [30] F. Terman, "Inductor," 7 12 2021. [Online]. Available: <https://en.wikipedia.org/wiki/Inductor>.
- [31] "Transistors PNP THT," 11 2007. [Online]. Available: <https://www.tme.eu/pl/details/2n6491/tranzystory-pnp-tht/onsemi/2n6491g/>.
- [32] "Naprawa końcówki mocy WS 442," 1 3 2009. [Online]. Available: <https://unitraklub.pl/temat/7300>.
- [33] R. Parzyszek, Interviewee, *Artificial Load PKNW-32-01*. [Interview]. 23 8 2021.
- [34] R. Parzyszek, "Prezentacja sztucznego obciążenia PKNW-32-01," 21 4 2019. [Online]. Available: <https://youtu.be/dDHIRzTzTA>.
- [35] P. Górecki, "ELEKTRONIKA DLA WSZYSTKICH Rezystory, cz 2," 2 1996. [Online]. Available: https://edw.elportal.pl/pdf/k01/02_09.pdf.
- [36] K. Popiel, "Obciążenie Wzmacniacza Rezystorami Podczas Prac Serwisowych," 22 8 2019. [Online]. Available: <https://unitraklub.pl/temat/19973?page=1#comment-64640>.
- [37] Arcol, "Aluminium Housed Resistors," 14 8 2012. [Online]. Available: <http://www.arcolresistors.com/wp-content/uploads/2014/03/HS-Datasheet.pdf>.
- [38] J. Morgan, "Electronics," 8 7 2020. [Online]. Available: <https://electronics.stackexchange.com/questions/509362/what-can-make-a-ceramic-capacitor-blow>.
- [39] Trimble, "SketchUp," Google, [Online]. Available: <https://www.sketchup.com/>.
- [40] Bonnier, "Surowce," 7 1 2022. [Online]. Available: <https://notowania.pb.pl/instrument/PBSALUMINIUM/aluminium>.
- [41] Plasticker, "Real Time Price List," 7 1 2022. [Online]. Available: https://plasticker.de/preise/pms_en.php?kat=Mahlgut&aog=A&show=ok&make=ok.
- [42] Yupen Electronic Co., Ltd., "IEC Inlet Filters," [Online]. Available: <https://www.tme.eu/Document/ff12419432855280ebf12bbd3a18ee92/YB-T1%20SERIES.pdf>.

[43] “PET-G Melting Temperature,” 2021. [Online]. Available: <http://en.calin.com.ro/izdt/petg-melting-temperature>.

[44] Matmatch, “Material: PET-G vs PLA,” 2020. [Online]. Available: <https://matmatch.com/learn/material/petg-vs-pla>.

[45] Makerbot, [Online]. Available: <https://www.thingiverse.com/>.

Images without a caption nor cross-reference were produced by the author of this thesis.